

Significant changes from the 2011 to the 2014 edition of ACI 318

Satyendra K. Ghosh

- The 2014 edition of American Concrete Institute (ACI)'s *Building Code Requirements for Structural Concrete (ACI 318-14)* and *Commentary (ACI 318R-14)* has undergone a complete reorganization from its 2011 edition.
- ACI 318-14 contains a number of significant technical changes, with some of the most important in chapter 18, "Earthquake Resistant Structures."
- Changes from ACI 318-11 to ACI 318-14 are discussed in this paper.

The American Concrete Institute (ACI) has published *Building Code Requirements for Structural Concrete (ACI 318-14)* and *Commentary (ACI 318R-14)*,¹ and it has been adopted by the 2015 *International Building Code (IBC)*.² Thus, whenever the 2015 IBC is adopted by a local jurisdiction, as it will be by the state of California on January 1, 2017, ACI 318-14 will be law within that jurisdiction.

As is fairly well known by now, ACI 318 has undergone a complete reorganization from its 2011 to its 2014 edition. In view of the effort involved in the reorganization, the initial expectation was that the number of technical changes in ACI 318-14 would be minimal. However, it did not end up that way. ACI 318-14 does contain a number of significant technical changes, some of the most important of which are found in chapter 18, "Earthquake Resistant Structures." Organizational changes from ACI 318-11³ to ACI 318-14 are discussed, followed by a chapter-by-chapter list of the significant technical changes. Throughout the paper, underlining is used to indicate text that was not in ACI 318-11 but has been added in ACI 318-14; striking out has been used to indicate text that was included in ACI 318-11 but has been deleted from ACI 318-14.

Organizational changes

Organization of ACI 318-11

The organization of ACI 318-11 followed a framework that was started with ACI 318-71.⁴ There have been eight editions in between, in 1977, 1983, 1989, 1995, 1999, 2002, 2005, and 2008, with the framework remaining essentially unchanged.

ACI 318-11, following initial chapters on materials and construction aspects, dealt with analysis and design and strength and serviceability requirements in two succeeding chapters. Next, there were three behavior-based chapters, one on flexure and axial loads, one on shear and torsion, and one on development and splices of reinforcement. The document then switched to member-based chapters: two-way slab systems, walls, and footings. Finally, there were chapters on precast concrete, composite concrete flexural members, prestressed concrete, shells and folded plate members, strength evaluation of existing structures, earthquake-resistant structures, and structural plain concrete. There were also four appendixes, including one on strut-and-tie models and one on anchoring to concrete.

Member-based organization in ACI 318-14

While the ACI 318 cycle that produced ACI 318-05⁵ and ACI 318-08⁶ was still in full swing, it was decided after long deliberation within ACI, in the course of which external input was actively sought and considered, that ACI 318 should be reorganized as a member-based document. The idea was that within each chapter devoted to a particular member type, such as beam or column, the user would find all the requirements necessary to design that particular member type. Cary Kopczynski,⁷ an ACI 318 committee member, says, “This will eliminate the need to flip through several chapters to comply with all of the necessary design requirements for a particular structural member, as was necessary with the old organization format. The code’s new design can be compared to a cookbook: all the ingredients for baking a cake such as eggs, flour, sugar, oil—along with the baking instructions—are in one chapter, instead of individual chapters on eggs, flour, and sugar.”

Toolbox chapters

One challenge in converting to a member-based organization was determining where to place design information that applies to multiple member types, such as development-length requirements. To repeat essentially the same information in multiple chapters did not make sense because that would make the ACI 318 standard much longer and more unwieldy, so the decision was made to house such information in “toolbox” chapters and to reference the information from the member-based chapters.

Overall changes

There are some overall changes in the makeup of ACI 318-14 that should be noted. There are two new chapters: chapter 4, “Structural System Requirements,” and chapter 12, “Diaphragms.”

Appendix B of ACI 318-11, “Alternative Provisions for Reinforced and Prestressed Concrete Flexural and Compression Members,” and appendix C, “Alternative Load and Strength Reduction Factors,” have been discontinued.

Appendix A, “Strut-and-Tie Models,” is now chapter 23, and appendix D, “Anchoring to Concrete,” is chapter 17 in the reorganized document. No changes of any significance have been made in the provisions of chapter 23 or appendix D.

Three other chapters have remained intact: chapter 20, now 27, “Strength Evaluation of Existing Structures;” chapter 21, now 18, “Earthquake-Resistant Structures;” and chapter 22, now 14, “Structural Plain Concrete.” There are significant technical changes in chapter 18 and none in chapter 27 or 14. Chapter 1, “General” (previously “General Requirements”); chapter 2, “Notation and Terminology” (previously “Notation and Definitions”), and chapter 3, “Referenced Standards” (previously “Materials”) are in the same category in the sense that they have remained essentially the same entities but with changes in content.

Chapter 16, “Precast Concrete,” and chapter 18, “Prestressed Concrete,” no longer exist as separate entities. The provisions of those chapters are now spread over several of the new chapters.

Chapter 19, “Shells and Folded Plates,” is no longer part of the reorganized document. ACI Committee 318, in collaboration with ACI-ASCE Committee 334, Concrete Shell Design and Construction, has developed ACI 318.2-14,⁸ whose contents match those of ACI 318-11 chapter 19. (The reader may wonder why this document was designated ACI 318.2 rather than ACI 318.1. This is because it was initially planned that ACI 318-11 chapter 22 on plain concrete would become a separate standard, ACI 318.1. The number was reserved for that purpose. It was later decided to place the contents of ACI 318-11 chapter 22 in ACI 318-14 chapter 14.)

Table 1 shows a side-by-side comparison of the organization of ACI 318-11 and ACI 318-14.

ACI 318-14 has no appendixes. It is likely that appendixes will be acquired in time because ACI 318 appendixes have served a useful purpose in the past by providing a home for material on its way into the standard (ACI 318-11 appendixes A and D, for example) or material on its way out (ACI 318-11 appendixes B and C, for example).

Table 1. Reorganization of ACI 318-14 compared with ACI 318-11

ACI 318-11		ACI 318-14		Comment
Description of provisions	Chapter and title	Description of provisions	Chapter and title	
Introductory	1 - General Requirements	Introductory	1 - General	
	2 - Notation and Definitions		2 - Notation and Terminology	
	3 - Materials		3 - Referenced Standards	
Materials/ construction	4 - Durability Requirements	Other	4 - Structural System Requirements	New
	5 - Concrete Quality, Mixing, and Placing		5 - Loads	
	6 - Formwork, Embedded Pipes, and Construction Joints		6 - Structural Analysis	
	7 - Details of Reinforcement		7 - One-Way Slabs	
Other	8 - Analysis and Design—General Considerations	Member-based	8 - Two-Way Slabs	
	9 - Strength and Serviceability Requirements		9 - Beams	
Behavior-based	10 - Flexure and Axial Loads	Member-based	10 - Columns	
	11 - Shear and Torsion		11 - Walls	
	12 - Development and Splices of Reinforcement		12 - Diaphragms	New
Member-based	13 - Two-Way Slab Systems	Other	13 - Foundation	
	14 - Walls		14 - Plain Concrete	Intact
	15 - Footings		15 - Beam-Column and Slab-Column Joints	
Other	16 - Precast Concrete	Connections	16 - Connections between Members	
	17 - Composite Concrete Flexural Members		17 - Anchoring to Concrete	Intact
	18 - Prestressed Concrete	Other	18 - Earthquake-Resistant Structures	Intact
	19 - Shells and Folded Plate Members	Materials	19 - Code Requirements for Thin Shells and Commentary	ACI 318.2
	20 - Strength Evaluation of Existing Structures		20 - Steel Reinforcement Properties, Durability, and Embedments	
	21 - Earthquake-Resistant Structures	Toolbox	21 - Strength Reduction Factors	
	22 - Structural Plain Concrete		22 - Sectional Strength	
	App. A - Strut-and-Tie Models		23 - Strut-and-Tie Models	Intact
	App. B - Alternative Provisions for Reinforced and Prestressed Concrete Flexural and Compression Members (discontinued)		24 - Serviceability Requirements	
	App. C - Alternative Load and Strength Reduction Factors (discontinued)	Construction	25 - Reinforcement Details	
App. D - Anchoring to Concrete	26 - Construction Documents and Inspection			
	Other	27 - Strength Evaluation of Existing Structures	Intact	

Construction documents and inspection

A unique chapter that the user will probably require some time to get used to is chapter 26, “Construction Documents and Inspection.” The chapter starts with the following:

26.1.1 This chapter addresses (a) through (c):

- (a) Design information that the licensed design professional shall specify in the construction documents,
- (b) Compliance requirements that the licensed design professional shall specify in the construction documents,
- (c) Inspection requirements that the licensed design professional shall specify in the construction documents.

Thus, construction and inspection requirements have been consolidated, and they are now related to construction documents. The construction requirements are designated either as “design information” or “compliance requirements.” These are largely existing materials that have been rearranged. The primary intent of these provisions is that the licensed design professional must now provide all of the construction requirements in the project drawings and specifications, rather than referring to ACI 318.

The inspection requirements in section 26.13 are taken from chapter 17 of the 2015 IBC² and were previously not part of ACI 318.

Technical changes

Chapter 1: General

General information regarding the scope and applicability of ACI 318 is provided.

A new section on interpretation is included to help users better understand the ACI 318 provisions.

Chapter 2: Notation and Terminology

Engineers are specifying use of interlocking headed deformed bars to form the legs of hoops. The use of interlocking headed bars is a concern because of the possibility that heads will not be adequately interlocked and because the heads could become disengaged under complex loadings well into the nonlinear range of response. Therefore, the definition for hoops has been modified as follows:

hoop — Closed tie or continuously wound tie, made up of one or several reinforcement elements, each having

seismic hooks at both ends. A closed tie shall not be made up of interlocking headed deformed bars.

A definition for special seismic systems, a term used in chapters 18 and 19, has been added:

special seismic systems — Structural systems that use special moment frames, special structural walls, or both.

Chapter 3: Referenced Standards

The following referenced specifications have been added to section 3.2.4:

- ASTM A370-14, *Standard Test Methods and Definitions for Mechanical Testing of Steel Products*⁹
- ASTM A1085-13, *Standard Specification for Cold-Formed Welded Carbon Steel Hollow Structural Sections (HSS)*¹⁰
- ASTM C173/C173M-14, *Standard Test Method for Air Content of Freshly Mixed Concrete by the Volumetric Method*¹¹
- ASTM C1582/C1582M-11, *Standard Specification for Admixtures to Inhibit Chloride-Induced Corrosion of Reinforcing Steel in Concrete*¹²

The following referenced specifications have been deleted:

- ASTM C109/C109M-08, *Standard Test Method for Compressive Strength of Hydraulic Cement Mortars (Using 2-in. or [50-mm] Cube Specimens)*¹³
- ASTM C192/C192M-07, *Standard Practice for Making and Curing Concrete Test Specimens in the Laboratory*¹⁴

Several referenced standards and specifications have been updated, as always happens with every new edition of ACI 318. Note that the edition of every referenced standard is important. ACI 318 does not necessarily adopt new editions of referenced standards unless they are vetted before the publication of each edition of the standard.

Chapter 4: Structural System Requirements

This chapter has been added to ACI 318-14 to introduce structural system requirements. This chapter contains sections on materials, design loads, structural system and load paths, structural analysis, strength, serviceability, durability, sustainability, structural integrity, fire resistance, requirements for specific types of construction, construction and inspection, and strength evaluation of existing structures. Most of these sections refer to other chapters

in ACI 318-14. The section on construction and inspection, for instance, refers to chapter 26. In the areas of sustainability and fire resistance, ACI 318-14 does not have specific requirements. The section on sustainability allows the licensed design professional to specify, in the construction documents, sustainability requirements in addition to the strength, serviceability, and durability requirements of ACI 318-14. The strength, serviceability, and durability requirements are required to take precedence over sustainability considerations, though these requirements are generally in harmony with sustainable structures. In the section on fire resistance, ACI 318 refers to the fire-protection requirements of the general building code, saying only that where “the general building code requires a thickness of concrete cover for fire protection greater than the concrete cover specified in 20.6.1, such greater thickness shall govern.” This would be the case anyway because 2015 IBC² section 102.4.1 explicitly states, “Where conflicts occur between provisions of this code and referenced codes and standards, the provisions of this code shall apply.”

Chapter 5: Loads

The following modification has been made in the provision for live load reduction because there are still unincorporated areas where there may not be a general building code:

5.2.3 — Live load reductions shall be permitted in accordance with the general building code or, in the absence of a general building code, in accordance with ASCE/SEI 7.

For many code cycles, ACI 318 retained provisions for service-level earthquake forces in design load combinations. In 1993, ASCE 7¹⁵ converted earthquake forces to strength-level forces and reduced the earthquake load factor to 1.0, and the model building codes followed suit. In modern building codes around the world, earthquake loads are now strength-level forces. Therefore, any references to service-level earthquake forces including the following ACI 318-11 section have been deleted:

9.2.1 (c) ~~Where E , the load effects of earthquake, is based on service-level seismic forces, $1.4E$ shall be used in place of $1.0E$ in Eq. (9-5) and (9-7).~~

A requirement to include secondary moments was properly included in the ACI 318-11 section on moment redistribution but was not included anywhere else. Because secondary moments are significant considerations when a member is being designed, including when moments are not redistributed, they should be included in the member chapters. Also, the effects of reactions induced by prestressing include more than just secondary moments, so the language is modified to reflect this. Two new sections should be noted:

5.3.11 — Required strength U shall include internal load effects due to reactions induced by prestressing with a load factor of 1.0.

7.4.1.3 — For prestressed slabs, effects of reactions induced by prestressing shall be considered in accordance with 5.3.11.

Sections 8.4.1.3 and 9.4.1.3 have, similarly, been added to the chapters on two-way slabs and beams, respectively.

Chapter 6: Structural Analysis

The following new item has been added in section 6.6.2.3:

(b) For frames or continuous construction, it shall be permitted to assume the intersecting member regions are rigid.

ACI 318 has so far been silent on the use of finite element analysis (FEA), though it is now frequently used. Chapter 6 has added section 6.9 with provisions that are intended to explicitly allow the use of FEA and to provide a framework for the future expansion of FEA provisions. It is not the purpose of the added provisions to serve as a guide toward the selection and use of FEA software. The new chapter on diaphragms and collectors makes an explicit reference to the use of FEA, which makes it imperative that ACI 318 recognize the acceptability of its use.

Chapter 8: Two-Way Slabs

ACI 318-11 section 18.9.1 required a minimum area of bonded reinforcement to be provided in all flexural members with unbonded tendons. The purpose of the minimum bonded reinforcement over the tops of columns is to distribute cracking caused by high local flexural tensile stresses in areas of peak negative moments. However, the high local tensile stresses are not unique to slabs with unbonded tendons. ACI 318-14 section 8.6.2.3 requires the same minimum bonded reinforcement in slabs with unbonded or bonded tendons, except that the area of bonded tendons is considered effective in controlling cracking.

ACI Committee 318 also decided that if the same bonded reinforcement were required for both bonded and unbonded post-tensioned two-way systems, the structural integrity requirements for both systems should also be the same. The structural integrity requirements in ACI 318-11 section 18.12.6 applied to two-way posttensioned slab systems with unbonded tendons only. The structural integrity requirements in ACI 318-14 section 8.7.5.6 now apply to two-way posttensioned slab systems with bonded as well as unbonded tendons.

Chapter 9: Beams

The use of open web reinforcement for torsion and shear in slender spandrel beams has been suggested by the precast



Figure 1. Precast concrete spandrel specimen tested at North Carolina State University. Image from Lucier et al., “Development of a Rational Design Methodology for Precast Concrete Slender Spandrel Beams: Part 1, Experimental Results” (2011).

concrete industry as an alternative to the closed stirrups traditionally mandated by ACI 318. Eliminating closed stirrups is desirable because they cause reinforcement congestion; production costs also increase significantly because pretensioning strand must be threaded through the closed stirrups.

An extensive PCI-sponsored experimental and analytical research program was conducted at North Carolina State University (NCSU).^{16,17} The objective was to develop a rational design procedure for slender precast concrete spandrel beams. Specifically, the research was aimed at simplifying the detailing requirements for the end regions of such beams. The end regions are often congested with heavy reinforcement cages when designed using current procedures.

Sixteen precast concrete spandrel beams were tested to failure (**Fig. 1**). All specimens were full-scale, most spanning 45 ft (13.7 m). Two of the test specimens were designed and detailed with closed stirrups, according to current practice, to serve as controls for the experimental program. The remaining specimens were designed with various configurations of open web reinforcement. Several specimens were specially configured to force failures in their end regions by adding extra ledge, flexural, and hanger reinforcement.

In addition to the experimental program, finite element models were developed (**Fig. 2**) and calibrated to experimental data. These models were used in conjunction with conventional analysis to corroborate the experimental results and to further investigate the behavior of slender precast concrete spandrel beams.

The results of this research demonstrated that properly designed open web reinforcement is a safe, effective, and efficient alternative to traditional closed stirrups for slender precast concrete spandrels. A simple, rational design procedure was developed. This proposed procedure significantly

reduces reinforcement congestion, especially in the end regions of slender spandrels, while maintaining a desired level of safety.

The relevant newly added ACI 318-14 section reads

9.5.4.7— For solid precast sections with an aspect ratio $h/b_t \geq 4.5$ [b_t = width of that part of cross section containing the closed stirrups resisting torsion, in.], it shall be permitted to use an alternative design procedure and open web reinforcement, provided the adequacy of the procedure and reinforcement have been shown by analysis and substantial agreement with results of comprehensive tests. The minimum reinforcement requirements of 9.6.4 and detailing requirements of 9.7.5 and 9.7.6.3 need not be satisfied.

The research at NCSU is referenced in commentary section C9.5.4.7.

Chapter 12: Diaphragms

ACI 318 has, for many editions, contained design and detailing requirements, found in ACI 318-11 section 21.11 or ACI 318-14 section 18.12, for diaphragms in structures assigned to seismic design category (SDC) D, E, or F, as defined in ASCE 7-10.¹⁸ ACI 318-14 has, for the first time, added design provisions in the new chapter 12 for diaphragms in buildings assigned to SDC C and lower. The new chapter applies “to the design of nonprestressed and prestressed diaphragms, including (a) through (d):

- (a) Diaphragms that are cast-in-place slabs
- (b) Diaphragms that comprise a cast-in-place topping slab on precast elements

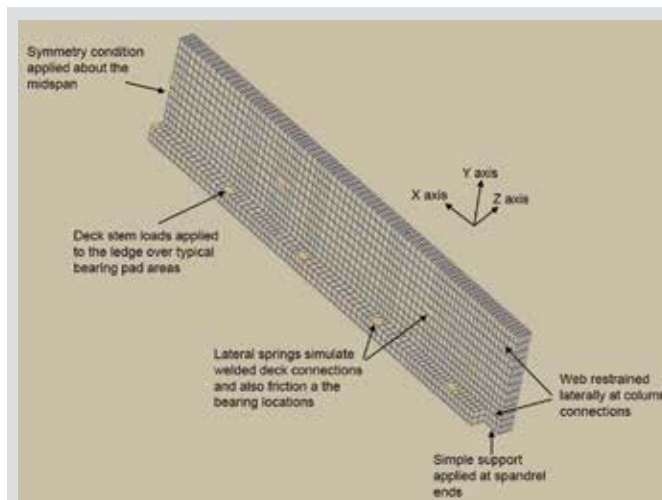

Figure 2. Finite element model of a precast concrete spandrel beam. Image from Lucier et al., “Development of a Rational Design Methodology for Precast Concrete Slender Spandrel Beams: Part 2, Analysis and Design Guidelines” (2011).



Figure 3. Precast concrete double-tee deck diaphragm. Image courtesy of Pat Hynes, Knife River Prestress Division, Harrisburg, Ore.

- (c) Diaphragms that comprise precast elements with end strips formed by either a cast-in-place concrete topping slab or edge beams
- (d) Diaphragms of interconnected precast elements without cast-in-place concrete topping.” (Fig. 3)

Chapter 12 follows the format of the other member-based chapters.

Chapter 18: Earthquake-Resistant Structures

There are a number of significant and substantive changes in this chapter.

Column confinement The ability of the concrete core of a reinforced concrete column to sustain compressive strains tends to increase with confinement pressure. Compressive strains caused by lateral deformation are additive to the strains caused by axial load. It follows that confinement reinforcement should be increased with axial load to ensure consistent lateral deformation capacity. The dependence of the amount of required confinement on the magnitude of axial load imposed on a column has been recognized by some codes from other countries (such as CSA A23.3-14¹⁹ and NZS 3101-06^{20,21}) but was not reflected in ACI 318 through its 2011 edition.

The ability of confining steel to maintain core concrete integrity and increase deformation capacity is also related to the layout of the transverse and longitudinal reinforcement. Longitudinal reinforcement that is well distributed and laterally supported around the perimeter of a column core provides more-effective confinement than a cage with larger, widely spaced longitudinal bars. Confinement effectiveness is a key parameter determining the behavior of confined concrete (Mander et al.²²) and has been incorporated into the CSA A23.3-14¹⁹ equation for

column confinement. ACI 318, through its 2011 edition, did not explicitly account for confinement effectiveness in determining the required amount of confinement. It instead assumed constant confinement effectiveness independent of how the reinforcement is distributed.

In view of this, confinement requirements for columns of special moment frames (section 18.7.5) Fig. 4) with high axial load ($P_u > 0.3A_g f'_c$, where P_u is the factored axial force, A_g is the gross area of concrete section; and f'_c is the specified compressive strength of concrete) or high concrete compressive strength ($f'_c > 10,000$ psi [6895 MPa]) are significantly different in ACI 318-14.

One important new requirement for special moment frame columns is as follows:

18.7.5.2 — Transverse reinforcement shall be in accordance with (a) through (f):

- (f) Where $P_u > 0.3A_g f'_c$ or $f'_c \geq 10,000$ psi in columns with rectilinear hoops, every longitudinal bar or bundle of bars around the perimeter of the column core shall have lateral support provided by the corner of a hoop or by a seismic hook, and the value of h_x shall not exceed 8 in. (Fig. 5). P_u shall be the largest value in compression consistent with factored load combinations including E .

where

h_x = maximum center-to-center spacing of longitudinal bars laterally supported by corners of crossties or hoop legs around the perimeter of the column

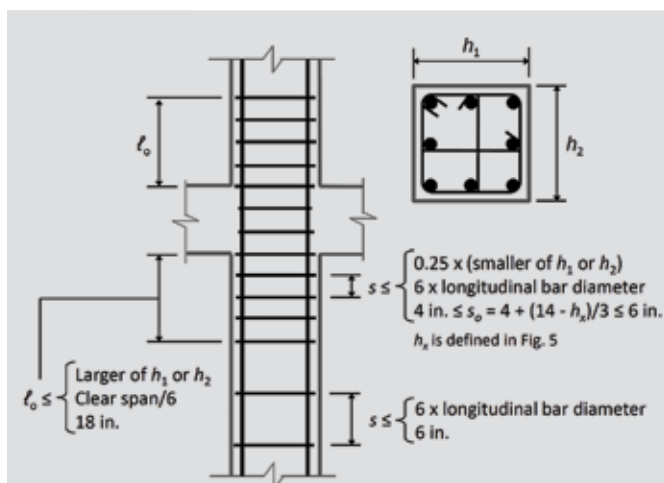

Figure 4. Confinement of rectangular column of special moment frame. Note: h_1 = plan dimension of column in one of two orthogonal directions; h_2 = plan dimension of column in other orthogonal direction; l_0 = length, measured from joint face along axis of member, over which special transverse reinforcement must be provided; s = center-to-center spacing of items, such as longitudinal reinforcement, transverse reinforcement, tendons, or anchors. 1 in. = 25.4 mm.

Table 2. Confinement of high-strength or highly axially loaded rectangular column of special moment frame in ACI 318-14

Transverse reinforcement	Conditions	Applicable expressions	
$\frac{A_{sh}}{sb_c}$ for rectilinear hoop	$P_u \leq 0.3 A_g f'_c$ and $f'_c \leq 10,000$ psi	Greater of (a) and (b)	$0.3 \left(\frac{A_g}{A_{ch}} - 1 \right) \frac{f'_c}{f_{yt}}$ (a)
	$P_u > 0.3 A_g f'_c$ and $f'_c > 10,000$ psi		Greater of (a), (b) and (c) $0.09 \frac{f'_c}{f_{yt}}$ (b) $0.2 k_f k_n \frac{P_u}{f_{yt} A_{ch}}$ (c)

Source: Data from ACI 318-14 Table 18.7.5.4.

Note: A_{ch} = cross-sectional area of a member measured to the outside edges of transverse reinforcement; A_g = gross area of concrete section; for a hollow section, A_g is the area of the concrete only and does not include the area of the void(s); A_{sb} = area of longitudinal reinforcement in shear wall boundary element; b_c = cross-sectional dimension of member core measured to the outside edges of the transverse reinforcement composing area A_{sh} ; f'_c = specified compressive strength of concrete; f_{yt} = specified yield strength of transverse reinforcement; k_f = concrete strength factor; k_n = confinement effectiveness factor; P_u = factored axial force, to be taken as positive for compression and negative for tension; s = center-to-center spacing of items, such as longitudinal reinforcement, transverse reinforcement, tendons, or anchors.

The change from prior practice is that instead of every other longitudinal bar having to be supported by a corner of a tie or a crosstie, every longitudinal bar will have to be supported when either the axial load on a column is high or the compressive strength of the column concrete is high.

The other new requirement for special moment frame columns is in the following section:

18.7.5.4 — Amount of transverse reinforcement shall be in accordance with Table 18.7.5.4 (reproduced here as Table 2).

The concrete strength factor k_f and confinement effectiveness factor k_n are calculated by (a) and (b).

$$k_f = \frac{f'_c}{25,000} + 0.6 \geq 1.0 \quad (18.7.5.4a)$$

$$k_n = \frac{n_l}{n_l - 2} \quad (18.7.5.4b)$$

where n_l is the number of longitudinal bars or bar bundles around the perimeter of a column core with rectilinear hoops that are laterally supported by the corner of hoops or by seismic hooks.

Special moment frame beam-column joints For beam-column joints of special moment frames, clarification of the development length of beam longitudinal reinforcement that is hooked, requirements for joints with headed longitudinal reinforcement, and restrictions on joint aspect ratio are new.

ACI 318 joint design provisions are based on the assumption that joint shear strength is provided mainly by a diagonal compression strut that develops across the joint. Joint transverse reinforcement confines the concrete strut, enabling it to resist shear under force reversals. The strut is most effective if the joint aspect ratio h_{beam}/h_{column} is close to 1.0, where h_{beam} is the overall depth of the beam and h_{column} is the overall depth of the column. For very large aspect ratios (Fig. 6), joint strength is likely to be reduced if a single strut is used. For such joints, additional transverse reinforcement might be required to support development of concrete struts that form at a shallower angle. It might also be necessary to modify the nominal joint shear strength

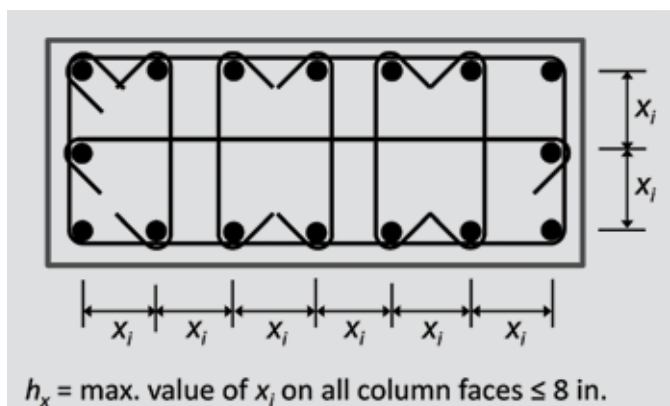

Figure 5. Confinement of high-strength or highly axially loaded rectangular column of special moment frame. Note: d_b = nominal diameter of bar, wire, or prestressing strand; h_x = maximum value of x_i on all column faces greater than 8 in.; x_i = dimension from centerline to centerline of laterally supported longitudinal bars. 1 in. = 25.4 mm.

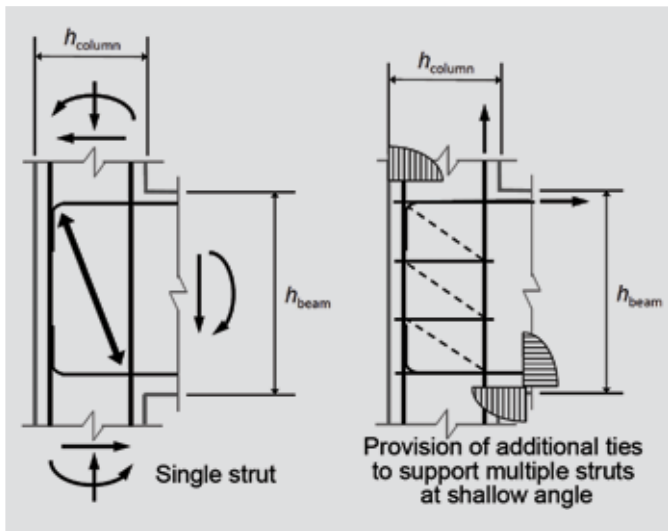

Figure 6. Joint with high aspect ratio. Note: h_{beam} = overall depth of beam; h_{column} = overall depth of column.

provisions in consideration of the steep strut (Fig. 6). Unfortunately, no tests on special moment frame joints with high aspect ratios have been reported in the literature. In view of this, ACI 318-14 section 18.8.2.4 restricts h_{beam}/h_{column} to a value of 2 or less.

The case of knee joints with headed beam reinforcement (Fig. 7) requires special consideration. In such joints, joint failure can occur by a diagonal crack that extends beyond the headed bars or by top-face blowout above the beam bars. ACI 318-14 section 18.8.3.4, therefore, requires that in such joints, “the column shall extend above the top of the joint a distance at least the depth h of the joint. Alternatively, the beam reinforcement shall be enclosed by additional vertical joint reinforcement providing equivalent confinement to the top face of the joint.”

ASCE-ACI 352 recommends²³ that where standard hooks are used, the hook should be bent into the joint, not away

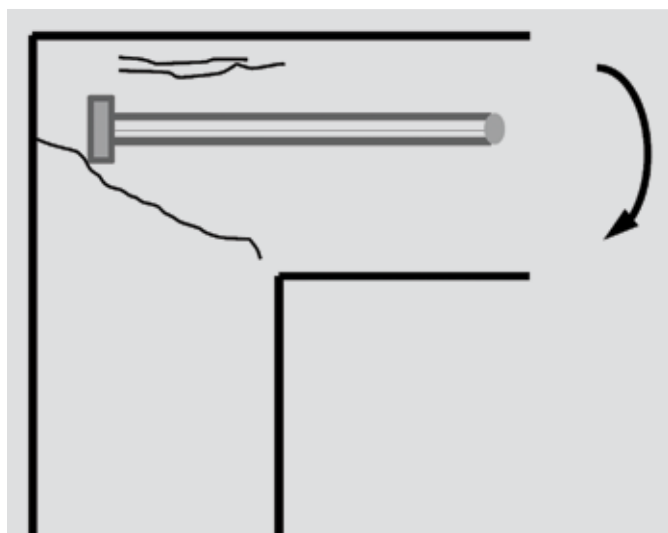

Figure 7. Knee joint with headed beam reinforcement.

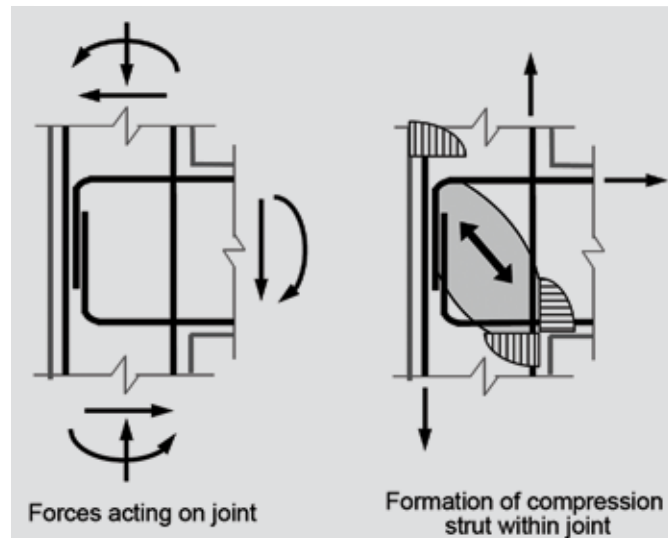

Figure 8. Bending of hooks into a joint.

from it. Bending the hook into the joint helps to develop a diagonal strut across the joint (Fig. 8). This strut is a critical part of joint shear resistance. Although it is widely understood that the hook must project into the joint (Fig. 8), ACI 318 never stated this explicitly. Some designers allow the hooks to be bent away from the joint at a contractor’s option. The tail of 90-degree hooks is now required to be bent into the joint (section 18.8.5.1).

Headed reinforcement was first introduced in ACI 318-08. Use of headed reinforcement was not mentioned in chapter 21 of ACI 318-08 or 318-11. However, headed reinforcement is increasingly used in beam-column joints of special moment frames, in part based on recommendations of ASCE-ACI 352²³ and in part based on the growing literature on the subject. ACI 318-08 section 12.6.1(f) required that the minimum clear spacing between headed bars be at least $4d_b$, where d_b is the nominal diameter of bar. The ASCE-ACI 352 recommendations do not constrain the spacing for headed bars. Numerous tests have now been reported on beam-column joints using headed bars; Kang et al.²⁴ summarize observations from tests on exterior beam-column joints. In consideration of the data presented there, ACI 318-14 now explicitly permits the use of headed reinforcement in beam-column joints of special moment frames and permits the clear spacing in such joints to be as small as $3d_b$ for bars in a layer (section 18.8.5.2).

Special shear walls Section 18.10, previously section 21.9, has been extensively revised in view of the performance of buildings in the Chile earthquake of 2010²⁵ and the Christchurch, New Zealand, earthquakes of 2011,²⁶ as well as performance observed in the 2010 E-Defense full-scale reinforced concrete building tests.²⁷ In these earthquakes and laboratory tests, concrete spalling and vertical reinforcement buckling were at times observed at wall boundaries.

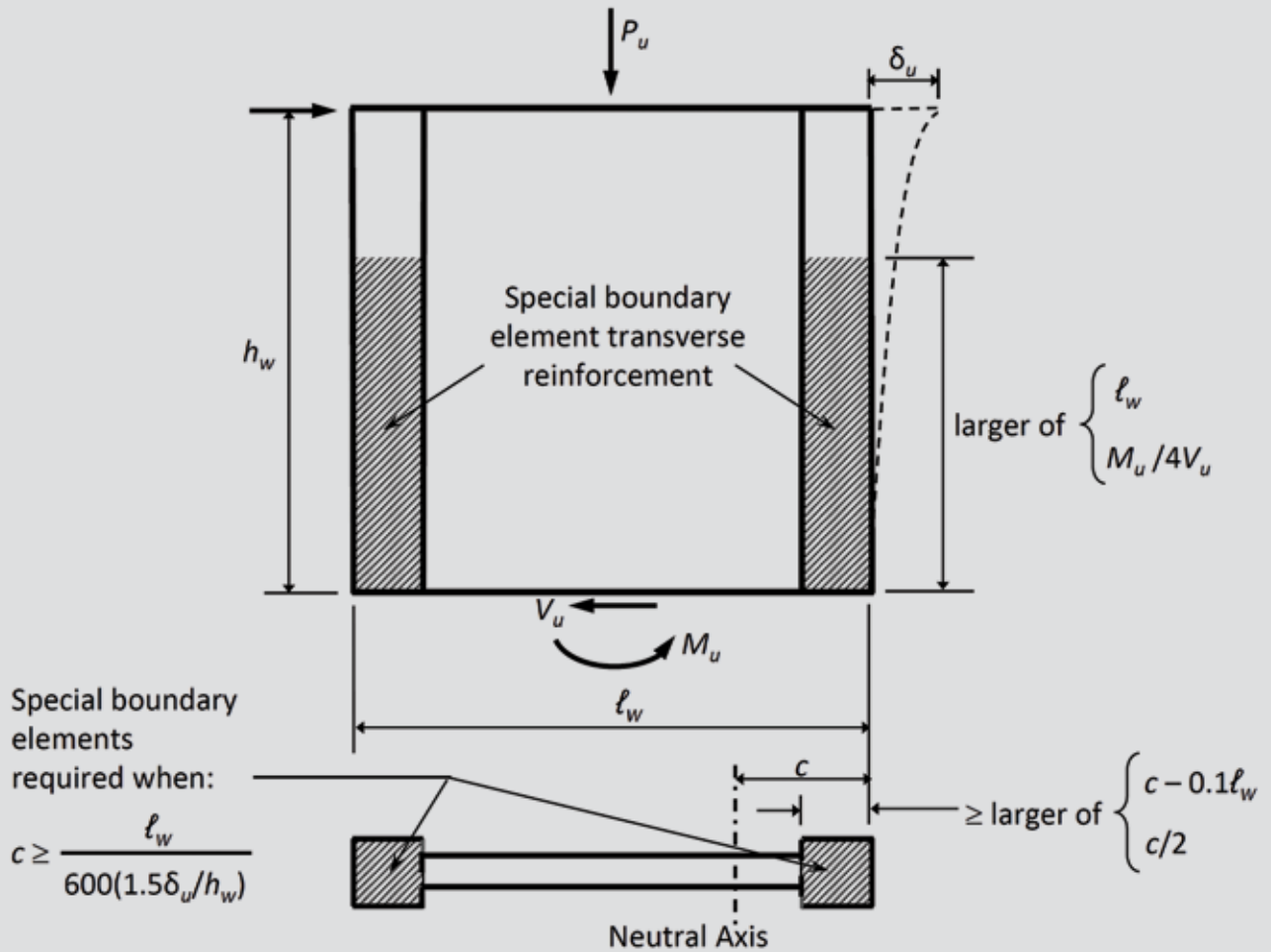

Figure 9. Specially confined boundary zone of special shear wall. Note: c = distance from extreme compression fiber to neutral axis; h_w = height of entire wall from base to top, or clear height of wall segment or wall pier considered; l_w = length of entire wall or length of wall segment or wall pier considered in direction of shear force; M_u = factored moment at section; P_u = factored axial force, to be taken as positive for compression and negative for tension; V_u = factored shear force at section; δ_u = design displacement.

Wall damage was often concentrated over a wall height of two or three times the wall thicknesses, much less than the commonly assumed plastic-hinge height of one-half the wall length. Out-of-plane buckling failures over partial story heights were also observed. This failure mode had previously been observed only in a few moderate-scale laboratory tests. Following are the significant changes.

- The displacement-based design procedure in section 18.10.6.2 has all along been applicable only to a cantilever wall with a critical section at the base. Another requirement is now added for the displacement-based design procedure to be applicable: the total height-to-total length ratio (h_w/l_w , where h_w is the height of entire wall from base to top, and l_w is the length of entire wall) of the wall must be no less than 2; in other words, the wall must be reasonably slender.

In the displacement-based approach, special confinement is required over a part of the compression zone:

$$c \geq \frac{l_w}{600(1.5\delta_u/h_w)} \quad (18.10.6.2)$$

where

c = largest neutral axis depth calculated for the factored axial force and nominal moment strength consistent with the direction of the design displacement δ_u (**Fig. 9**)

The 1.5 factor has been inserted in the denominator in ACI 318-14. Thus, more shear walls will require confined boundary zones under ACI 318-14 than under ACI 318-11. There were four considerations behind the insertion:

- The deflection amplification factor C_d of ASCE 7 may underestimate displacement response.
- Because collapse prevention under the maximum

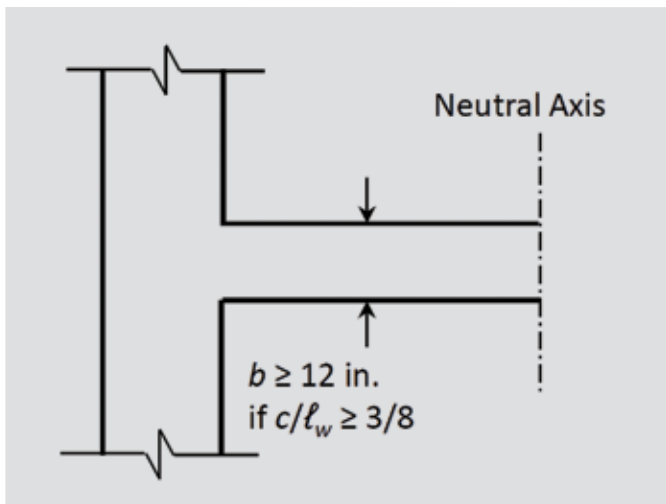

Figure 10. Minimum thickness of compression zone of special shear wall that is not tension controlled. Note: b = width of compression face of member; c = distance from extreme compression fiber to neutral axis; l_w = length of entire wall or length of wall segment or wall pier considered in direction of shear force. 1 in. = 25.4 mm.

considered earthquake is the prime objective of IBC/ASCE 7 seismic design, maybe displacements caused by the maximum considered earthquake, rather than the design earthquake, should be considered. The maximum considered earthquake is 150% as strong as the design earthquake.

- There is dispersion in seismic response, making it desirable to aim at an estimate that is not far from the expected upper-bound response.
- Damping may be lower than the 5% value assumed in the ASCE 7 design spectrum. The 1.5 factor is applied to the design displacement to emphasize that it is the design displacement that is modified (rather than changing the constant in the denominator to 900).

The lower limit of $\delta_u/h_w = 0.007$ in Eq. (21-8) of ACI 318-11 is changed to $0.007/1.5 = 0.0047$ (0.005) to be consistent with this change. The commentary already says, “The lower limit of 0.005 on the quantity δ_u/h_w , requires moderate wall deformation capacity for stiff buildings.” The following new sentence has been added, “The lower limit of 0.005 on the quantity δ_u/h_w , requires special boundary elements if wall boundary longitudinal reinforcement tensile strain does not reach approximately twice the limit used to define tension-controlled beam sections according to 21.2.2.”

- ACI 318-14 Eq. (18.10.6.2) is based on the assumption that yielding at the assumed critical section occurs over a plastic hinge height of one-half of the wall length. In order to achieve this spread of plasticity, either the wall section should be tension controlled or the compression zone must remain stable when subjected to large compressive strains (transition or

compression-controlled section). Observations from the 2010 Chile earthquake, corroborated by the 2010 E-Defense tests, indicate that brittle failures are possible for thin walls. Two changes have been made in view of this observation. First, the sentence noted in the previous bullet has been added to the commentary section R18.10.6.2. Second, a minimum wall thickness of 12 in. (300 mm) is imposed throughout the specially confined boundary zone where the wall section is not tension controlled (18.10.6.4[c]) (**Fig. 10**).

- Required transverse reinforcement for specially confined boundary zones of special shear walls has traditionally been determined using provisions for potential hinging regions of special moment frame columns. In the plastic hinge region of a special moment frame column, the minimum cross-sectional area of transverse reinforcement must be the larger amount given by ACI 318-14 Eq. (20.7.5.4b) and (20.7.5.4c) (old Eq. [21-4] and [21-5]). In the case of specially confined boundary zones of special shear walls, however, two exceptions were made. Eq. (21-4) or ACI 318-14 Eq. (20.7.5.4b) was declared inapplicable, and the maximum spacing limitation of one-quarter the minimum plan dimension was relaxed to one-third. Equation (20.7.5.4b) is no longer inapplicable. As to the minimum cross-sectional area of transverse reinforcement, there is no difference now between a special moment frame column hinging region and the specially confined boundary zone of a special shear wall.

In addition, the maximum center-to-center horizontal spacing of crossties and hoop legs h_x of 14 in. (360 mm) has been found not to provide sufficient confinement to thin walls. Based on laboratory tests by Thomsen and Wallace,²⁸ the maximum center-to-center horizontal spacing of crossties and hoop legs is now restricted to the lesser of two-thirds the wall thickness or 14 in. (section 18.10.6.4[e]).

- No slenderness limits existed in ACI 318-11 section 21.9 for specially confined boundary zones, primarily because this failure mode had only been observed in moderate-scale laboratory tests. Observations of wall instabilities following the recent earthquakes in Chile²⁵ and New Zealand²⁶ prompted a reexamination of this issue.

The 1997 *Uniform Building Code* (UBC)²⁹ included a limit of $l_u/16$ for special boundary elements, and both the Canadian¹⁹ and New Zealand^{20,21} codes include more restrictive limits, where l_u is the unsupported length of the column or wall.

Observations of wall performance in recent earthquakes and laboratory tests indicate that slender walls, which typically have low shear stress, are susceptible

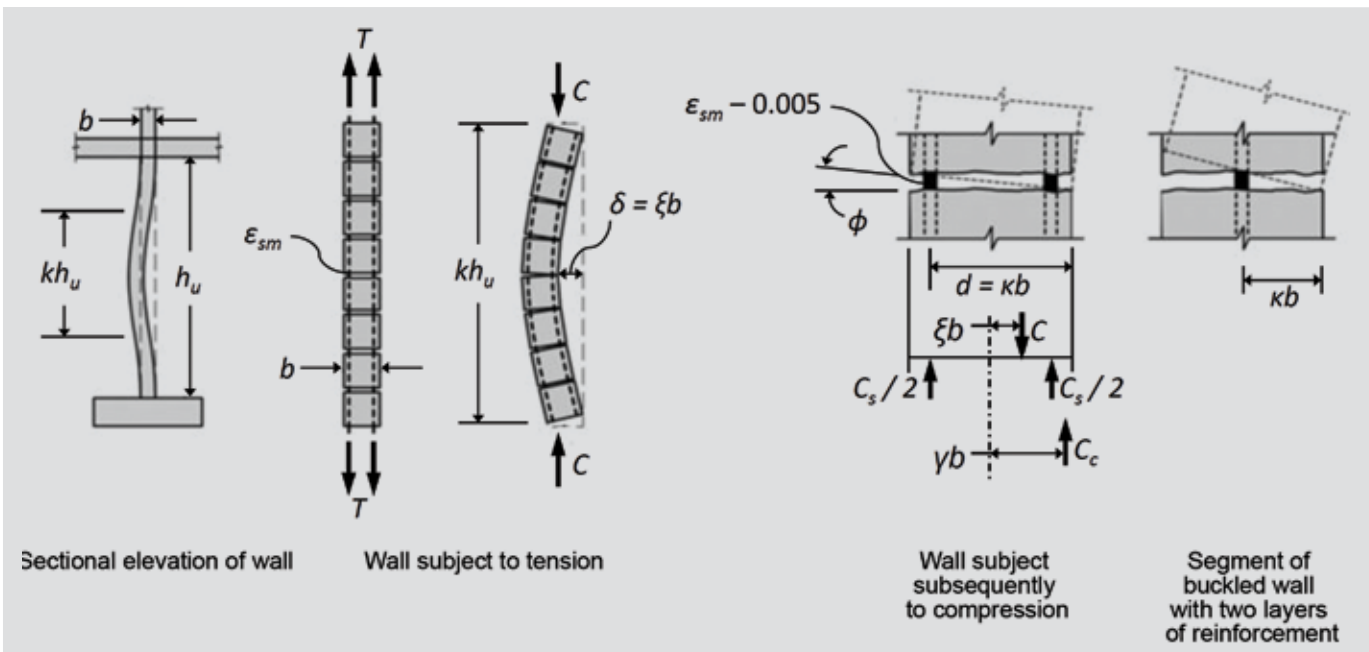

Figure 11. Lateral instability of wall boundary previously yielded in tension. Image from NIST (2014). Note: b = width of compression face of member; C = externally applied compression force on section; C_c = compression concrete force; C_s = force in tension reinforcement; d = distance from extreme compression fiber to centroid of longitudinal tension reinforcement; h_u = laterally unsupported height at extreme compression fiber of wall or wall pier, equivalent to ℓ_u for compression members; k = effective length factor; ℓ_u = unsupported length of column or wall; T = externally applied tensile force on section; γ = distance of line of application of compression concrete force from neutral axis divided by total depth of section; δ = maximum out-of-plane deflection; ε_{sm} = strain in reinforcement at the section of maximum deflection; κ = ratio of effective depth to total depth of section; ξ = ratio of maximum out-of-plane deflection to member depth; ϕ = sectional curvature.

to lateral instability failures. In ACI 318-11 section 21.9.2, a single curtain of web reinforcement was allowed as long as V_u did not exceed $2A_{cv}\lambda\sqrt{f'_c}$, where A_{cv} is the gross area of concrete section bounded by web thickness and length of section in the direction of shear force considered in the case of walls, and the gross area of concrete section in the case of diaphragms, not to exceed the thickness times the width of the diaphragm. Use of a single curtain of web reinforcement makes these walls more susceptible to instability failure. This is because following yielding of the longitudinal reinforcement in tension, a single layer of vertical web reinforcement lacks a mechanism to restore stability (**Fig. 11**).³⁰

Two changes have been made to address these issues:

- limit the slenderness ratio at all specially confined boundary zones to $\ell_u/16$ (section 18.10.6.4b) (**Fig. 12**)
- require two curtains of web reinforcement in all walls having $h_w/\ell_w \geq 2.0$ (section 18.10.2.2)
- Cyclic load reversals may lead to buckling of boundary longitudinal reinforcement even in cases where the demands on the boundary of the wall do not require special boundary elements. For walls with a boundary longitudinal reinforcement ratio exceeding a certain threshold value, ties are required to inhibit buckling (**Fig. 13**). The longitudinal reinforcement ratio is

intended to include only the reinforcement at the wall boundary, as indicated in Fig. 13.

The following changes have been made in the nonspecial confinement requirements of section 18.10.6.5(a):

The longitudinal spacing of transverse reinforcement at the wall boundary shall not exceed the lesser of 8 in. and $8d_b$ of the smallest primary flexural reinforcing bars, except the spacing shall not exceed the lesser of 6 in. and $6d_b$ within a distance equal to the greater of ℓ_w and $M_u/4V_u$ above and below critical sections where yielding of longitudinal reinforcement is likely to occur as a result of inelastic lateral displacements.

where

M_u = factored moment at section

V_u = factored shear force at section

- The commentary to ACI 318-14 has added two useful figures summarizing the boundary confinement requirements for walls with $h_w/\ell_w \geq 2$ and a single critical section controlled by flexure and axial load. One figure (**Fig. 14**, which is a reproduction of ACI 318-14 Fig. R18.10.6.4.2a) is for walls designed by the displacement-based approach of sections 18.10.6.2, 18.10.6.4, and 18.6.5. The other figure (**Fig. 15**, which is a reproduction of ACI 318-14 Fig. R18.10.6.4.2b) is

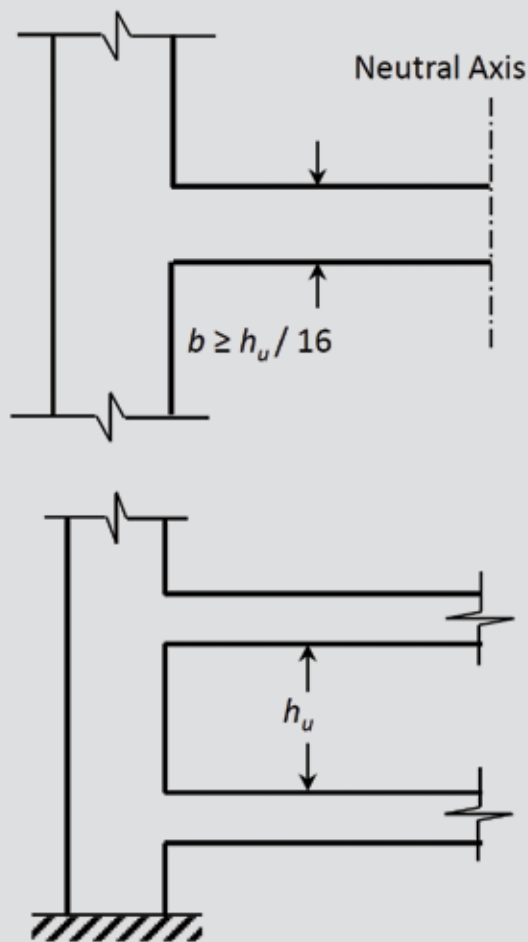

Figure 12. Minimum thickness of compression zone of special shear wall. Note: b = width of compression face of member; h_u = laterally unsupported height at extreme compression fiber of wall or wall pier, equivalent to ℓ_u for compression members; ℓ_u = unsupported length of column or wall.

for walls designed by the traditional approach of sections 18.10.6.3, 18.10.6.4, and 18.10.6.5.

Chapter 19: Concrete: Design and Durability Requirements

Quite a few significant changes have been made in this chapter.

- ACI 318-11 section 5.1.5, which says, “Splitting tensile strength tests shall not be used as a basis for field acceptance of concrete,” and commentary section R5.1.5 have been deleted because ACI 318-14 section 19.2.1.2 clearly says, “The specified compressive strength shall be used for mixture proportioning in 26.4.3 and for testing and acceptance of concrete in 26.12.3.”
- The tensile strength and all related properties of concrete are considered by ACI 318 to be functions of $\sqrt{f'_c}$. To determine all such properties for lightweight concrete, a multiplier of λ is applied to $\sqrt{f'_c}$ in all

applicable provisions of ACI 318-14. The multiplier is as given in Table 19.2.4.2 or as permitted in section 19.2.4.3. For concrete using normalweight fine aggregate, the table permits λ to be linearly interpolated between 0.75 and 0.85 based on the absolute volume of normalweight fine aggregate as a fraction of the total absolute volume of fine aggregate. For concrete using normalweight coarse aggregate, the table also permits λ to be linearly interpolated between 0.85 and 1.00 based on the absolute volume of normalweight coarse aggregate as a fraction of the total absolute volume of coarse aggregate. The following paragraph has been added to the commentary section R19.2.4 to help with this interpolation: “Typically, the designer will not know the blends of aggregate necessary to achieve the target design strength and density required for a project. In most cases, local concrete and aggregate suppliers have standard lightweight concrete mixtures and can provide the volumetric fractions of lightweight and normalweight aggregates necessary to achieve the target values. These volumetric fractions can be used to determine the value of λ , or in the absence of such data, it is permissible to use the lower-bound value of λ for the type of lightweight concrete specified.”

- ACI 318-11 Table 4.2.1 (reproduced here as **Table 3**), Exposure Categories and Classes, is now ACI 318-14 Table 19.3.1.1 (reproduced here as **Table 4**). A number of changes have been made in this table:
 - The column titled “Severity” has been deleted from the table.
 - Conditions describing exposure classes F1, F2, and F3 have changed. “Occasional exposure to moisture” has been replaced by “limited exposure to water.”
 - “Continuous contact with moisture” has been replaced by “frequent exposure to water.”
 - Exposure classes P0 and P1 (P for permeability) are now W0 and W1 (W for contact with water) because permeability is not an exposure condition.
- ACI 318-11 Table 4.3.1, Requirements for Concrete by Exposure Class, is now Table 19.3.2.1.

The maximum water–cementitious material ratio and the minimum compressive strength requirements for exposure classes F1 and F3 have changed (**Table 5**).

The cementitious material types that are allowed in concrete assigned to exposure classes S1, S2, and S3 have changed (**Table 6**). Since 2009, ASTM C595³¹

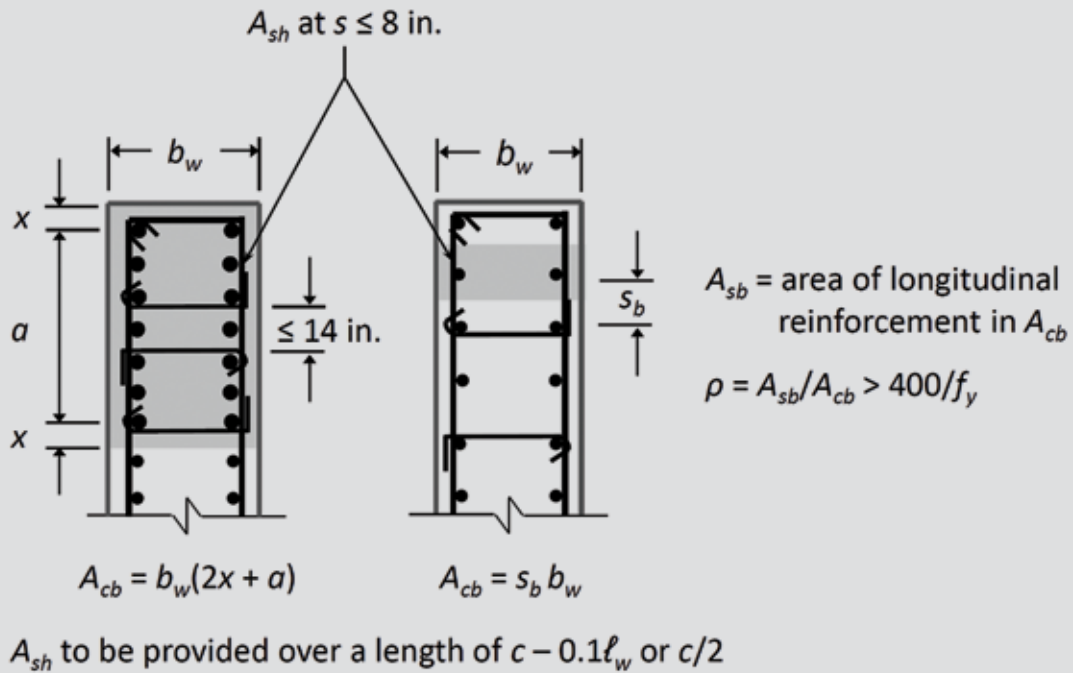

Figure 13. Local reinforcement ratio at shear wall boundary. Note: a = distance between first and last layers of concentrated flexural reinforcement at end of wall; A_{cb} = concrete area of shear wall boundary element; A_{sb} = area of longitudinal reinforcement in shear wall boundary element; A_{sh} = total cross-sectional area of transverse reinforcement, including crossies, within spacing s and perpendicular to dimension b_c ; b_w = web width or diameter of circular section; c = distance from extreme compression fiber to neutral axis; f_y = specified yield strength for nonprestressed reinforcement; ℓ_w = length of entire wall or length of wall segment or wall pier considered in direction of shear force; s = center-to-center spacing of items, such as longitudinal reinforcement, transverse reinforcement, tendons, or anchors; s_b = spacing of longitudinal reinforcement in shear wall boundary element; x = cover from center of extreme layer of concentrated flexural reinforcement to extremity of wall. 1 in. = 25.4 mm.

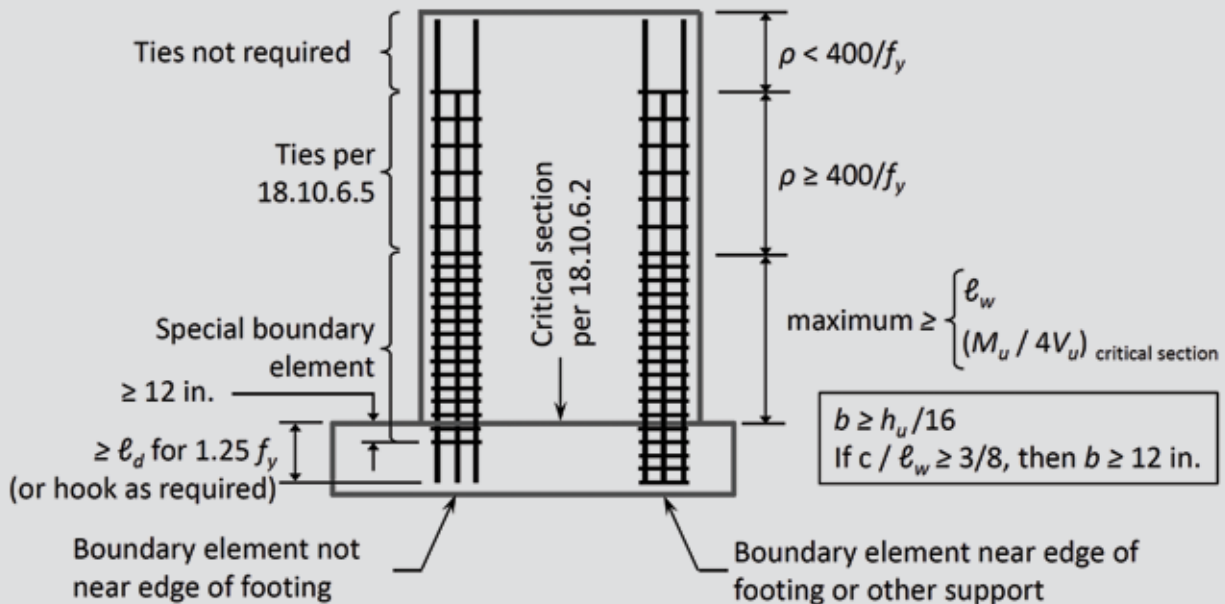
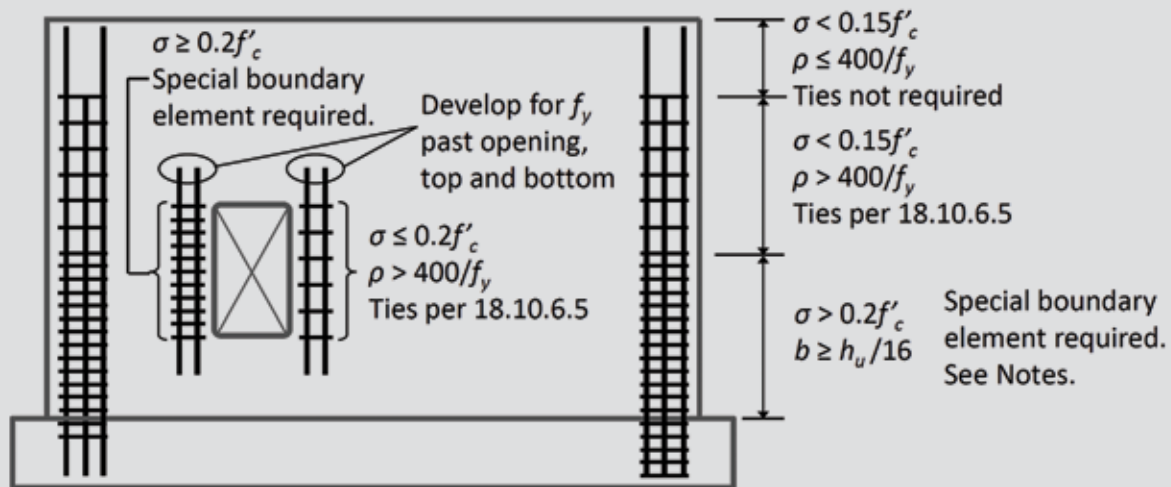

Figure 14. Summary of boundary confinement requirements for walls with $h_w/\ell_w \geq 2$, a single critical section controlled by flexure and axial load, and designed by the displacement-based approach of sections 18.10.6.2, 18.10.6.4, and 18.6.5. Note: b = width of compression face of member; c = distance from extreme compression fiber to neutral axis; f_y = specified yield strength for nonprestressed reinforcement; h_w = laterally unsupported height at extreme compression fiber of wall or wall pier, equivalent to ℓ_u for compression members; h_u = height of entire wall from base to top or clear height of wall segment or wall pier considered; ℓ_d = development length in tension of deformed bar, deformed wire, plain and deformed welded-wire reinforcement, or pretensioned strand; ℓ_u = unsupported length of column or wall; ℓ_w = length of entire wall or length of wall segment or wall pier considered in direction of shear force; M_u = factored moment at section; V_u = factored shear force at section; $\rho = A_{sb}/A_{cb}$. 1 in. = 25.4 mm. Reproduced with permission from the American Concrete Institute (ACI 318-14 Figure R18.10.6.4.2a).



Notes: Requirement for special boundary element is triggered if maximum extreme fiber compressive stress $\sigma \geq 0.2f'_c$. Once triggered, the special boundary element extends until $\sigma < 0.15f'_c$. Since $h_w / \ell_w \leq 2.0$, 18.10.6.4(c) does not apply.

Figure 15. Summary of boundary confinement requirements for walls with $h_w / \ell_w \geq 2$, with a single critical section controlled by flexure and axial load, and designed by the traditional approach of sections 18.10.6.3, 18.10.6.4, and 18.10.6.5. Note: b = width of compression face of member; f'_c = specified compressive strength of concrete; f_y = specified yield strength for nonprestressed reinforcement; h_u = laterally unsupported height at extreme compression fiber of wall or wall pier, equivalent to ℓ_u for compression members; h_w = height of entire wall from base to top or clear height of wall segment or wall pier considered; ℓ_u = unsupported length of column or wall; ℓ_w = length of entire wall, or length of wall segment or wall pier considered in direction of shear force; $\rho = A_{sv} / A_{cb}$; σ = extreme fiber compressive stress in concrete. Reproduced with permission from the American Concrete Institute (ACI 318-14 Figure R18.10.6.4.2b).

has included requirements for binary (IP and IS) and ternary (IT) blended cements.

- In section 19.3.3 (ACI 318-11 section 4.4), a new section 19.3.3.2 has been added that requires that “Concrete shall be sampled in accordance with ASTM C172, and air content shall be measured in accordance with ASTM C231 or ASTM C173.”^{11,32,33} ASTM C231 (pressure method) is commonly used for normalweight concrete and ASTM C173¹¹ (volumetric method) for lightweight concrete.
- The new commentary section 19.3.3.2 clarifies that ACI 318 requirements for air content apply to fresh concrete sampled at the point of discharge from a mixer or a transportation unit upon arrival on-site. If the licensed design professional requires sampling and acceptance of fresh concrete air content at another point, appropriate requirements must be included in the construction documents.
- The footnotes to ACI 318-11 Table 4.4.1, Total Air Content of Concrete Exposed to Freezing and Thawing, are deleted from Table 19.3.3.1. The first footnote is not pertinent to the table, and the information in the second footnote is contained in the ASTM test methods cited in section 19.3.3.2.

Chapter 20: Steel Reinforcement Properties, Durability, and Embedments

A major change in this chapter is a change in the definition of the yield strength of reinforcement.

ACI 318-08 section 3.5.3.2, which was unchanged from the 1971 to 2008 editions of ACI 318, read, “Deformed reinforcing bars shall conform to one of the ASTM specifications listed in 3.5.3.1 except that for bars with specified yield strength f_y exceeding 60,000 psi [414 MPa], the yield strength shall be taken as the stress corresponding to a strain of 0.35 percent.”

In ACI 318-11, this requirement became “Deformed reinforcing bars shall conform to one of the ASTM specifications listed in 3.5.3.1, except that for bars with f_y less than 60,000 psi (414 MPa), the yield strength shall be taken as the stress corresponding to a strain of 0.5 percent, and for bars with f_y at least 60,000 psi, the yield strength shall be taken as the stress corresponding to a strain of 0.35 percent.”

This definition has changed in a major way in ACI 318-14. For reinforcement without a sharply defined yield point, yield strength is now based on the 0.2% offset method (Fig. 16), as in ASTM specifications. The change was initi-

Table 3. Exposure categories and classes in ACI 319-11

Category	Severity	Class	Condition	
Freezing and thawing (F)	Not applicable	F0	Concrete not exposed to freezing-and-thawing cycles	
	Moderate	F1	Concrete exposed to freezing-and-thawing cycles and occasional exposure to moisture	
	Severe	F2	Concrete exposed to freezing-and-thawing cycles and in continuous contact with moisture	
	Very severe	F3	Concrete exposed to freezing-and-thawing cycles and in continuous contact with moisture and exposed to deicing chemicals	
Sulfate (S)	Severity	Class	Water soluble sulfate (SO ₄) in soil, percentage by mass*	Dissolved sulfate (SO ₄) in water, ppm†
	Not applicable	S0	SO ₄ < 0.10	SO ₄ < 150
	Moderate	S1	0.10 ≤ SO ₄ < 0.20	150 ≤ SO ₄ < 1500 or seawater
	Severe	S2	0.20 ≤ SO ₄ ≤ 2.00	1500 ≤ SO ₄ < 10,000
	Very severe	S3	SO ₄ > 2.00	SO ₄ > 10,000
Requiring low permeability (P)	Not applicable	P0	In contact with water where low permeability is not required	
	Required	P1	In contact with water where low permeability is required	
Corrosion protection of reinforcement (C)	Not applicable	C0	Concrete dry or protected from moisture	
	Moderate	C1	Concrete exposed to moisture but not to an external source of chlorides	
	Severe	C2	Concrete exposed to moisture and an external source of chlorides from deicing chemicals, salt, brackish water, seawater, or spray from these sources	

Source: Data from ACI 318-11 Table 4.2.1.

* Percentage sulfate by mass in soil shall be determined by ASTM C1580.

† Concentration of dissolved sulfates in water in parts per million shall be determined by ASTM D516 or ASTM D4130.

ated when a task group was formed under ACI 318 Subcommittee B to reassess yield measurement methodologies in light of the actual stress-strain behavior of currently produced nonprestressed steel reinforcement products. The task group conducted a parametric study that performed analytical predictions of actual sectional strength for numerous beams and columns, as reported by Paulson et al.³⁴

Normalized stress-strain relationships were developed for Grade 60 (414 MPa) and Grade 80 (552 MPa) reinforcement, both sharply yielding and gradually yielding, based on observed actual stress-strain behavior. As used here, *normalized* means that the gradually yielding stress-strain curve develops exactly the specified yield strength when yield is measured according to the criteria being considered (based on 0.35% elongation under load, 0.2% offset method, and so forth). Also included in the parametric study were code-based nominal sectional strengths.

Beam sections were found to have predicted analytical strengths that were always in excess of code-calculated nominal strengths, even when the reinforcement was grad-

ually yielding and the yield strength definition was based on the 0.2% offset method. Also, only certain heavily reinforced sections were found to have predicted strengths as low as 95% of code nominal strength when reinforcement was gradually yielding and the yield strength definition was based on the 0.2% offset method.

The yield measurement method for gradually yielding nonprestressed steel reinforcement became the offset method (using an offset of 0.2%) because of the following:

- Heavily reinforced column sections are less practical.
- Actual strengths are no more than 5% below code-predicted strengths.
- Gradually yielding reinforcement is an infrequent occurrence (estimated to be at most a few percent of current ASTM A615 and A706 bars).^{35,36}
- The sections with the lowest actual strengths compared with code-predicted strengths are compression-

Table 4. Exposure categories and classes in ACI 318-14

Category	Class	Condition	
Freezing and Thawing (F)	F0	Concrete not exposed to freezing-and-thawing cycles	
	F1	Concrete exposed to freezing-and-thawing cycles with limited exposure to water	
	F2	Concrete exposed to freezing-and-thawing cycles with frequent exposure to water	
	F3	Concrete exposed to freezing-and-thawing cycles with frequent exposure to water and exposure to deicing chemicals	
Sulfate (S)	Class	Water-soluble sulfate (SO ₄) in soil, percentage by mass*	Dissolved sulfate (SO ₄ ²⁻) in water, ppm†
	S0	SO ₄ ²⁻ < 0.10	SO ₄ ²⁻ < 150
	S1	0.10 ≤ SO ₄ ²⁻ < 0.20	150 ≤ SO ₄ ²⁻ < 1500 or seawater
	S2	0.20 ≤ SO ₄ ²⁻ ≤ 2.00	1500 ≤ SO ₄ ²⁻ < 10,000
	S3	SO ₄ ²⁻ > 2.00	SO ₄ ²⁻ > 10,000
In contact with water (W)	W0	In contact with water where low permeability is not required	
	W1	In contact with water where low permeability is required	
Corrosion protection of reinforcement (C)	C0	Concrete dry or protected from moisture	
	C1	Concrete exposed to moisture but not to an external source of chlorides	
	C2	Concrete exposed to moisture and an external source of chlorides from deicing chemicals, salt, brackish water, seawater, or spray from these sources	

Source: Data from ACI 318-14 Table 19.3.1.1.

* Percentage sulfate by mass in soil shall be determined by ASTM C1580.

† Concentration of dissolved sulfates in water in parts per million shall be determined by ASTM D516 or ASTM D4130.

controlled with a ϕ -factor of 0.65, providing for a still ample margin of safety. The 0.2% offset method is selected because it is the most common method used in the steel products manufacturing industry. This change aligns ACI 318 with common industry practice while not adversely affecting the structural safety of reinforced concrete members.

There are other changes in chapter 20 as well.

Deformed and plain stainless steel wire and welded wire

conforming to ASTM A1022³⁷ is now permitted to be used as concrete reinforcement.

Section 20.2.2.5 requires “Deformed nonprestressed longitudinal reinforcement resisting earthquake induced moment, axial force, or both, in special moment frames, special structural walls, and all components of special structural walls including coupling beams and wall piers” to be ASTM A706³⁶ Grade 60 (414 MPa). ASTM A615³⁵ Grade 40 (276 MPa) or Grade 60 reinforcement is permitted if two supplementary requirements are met, which are already part of the ASTM A706 specification. A third supplementary requirement is now added for ASTM A615 Grade 60 reinforcement to be permitted for use in special moment frames and special shear walls. The minimum elongation in 8 in. (200 mm) must now be the same as that for ASTM A706 Grade 60 reinforcement.

The stress in prestressing steel at the stage of strength f_{ps} can be calculated based on strain compatibility or is permitted to be calculated in accordance with Eq. (20.3.2.3.1) for members with bonded prestressed reinforcement if the effective prestress is no smaller than one-half the tensile strength of the prestressing reinforcement. The

Table 5. Comparison of requirements for concrete by exposure class between ACI 318-14 and ACI 318-11

Exposure class	ACI 318-11		ACI 318-14	
	Maximum w/cm	Minimum f'_c , psi	Maximum w/cm	Minimum f'_c , psi
F1	0.45	4500	0.55	3500
F3	0.45	4500	0.40	5000

Note: f'_c = specified compressive strength of concrete; w/cm = water-cementitious materials ratio. 1 psi = 6.985 kPa.

Table 6. Comparison of restrictions on cementitious-material types by exposure class between ACI 318-14 and ACI 318-11

Exposure class	Cementitious-material types permitted by ASTM C595	
	ACI 318-11	ACI 318-14
S0	No type restriction	No type restriction
S1	IP (MS), IS (<70)(MS)	Types IP, IS, or IT with (MS) designation
S2	IP (HS), IS (<70)(HS)	Types IP, IS, or IT with (HS) designation
S3	IP (HS) + pozzolan or slag II or IS (<70)(HS) + pozzolan or slag	Types IP, IS, or IT with (HS) designation plus pozzolan or slag cement

Note: HS = high sulfate resistance; IP = portland-pozzolan cement; IS = portland blast-furnace slag cement; IT = ternary blended cement; MS = moderate sulfate resistance.

commentary to this provision in ACI 318-11 indicated that the use of then-Eq. (18-1) was appropriate only if all prestressed reinforcement is in the tension zone. Therefore, ACI 318-14 now requires that for Eq. (20.3.2.3.1) to be applicable, all prestressing reinforcement must be in the tension zone.

Chapter 22: Sectional Strength

Following are the changes in chapter 22:

- For prestressed members, a new equation for the nominal axial strength at zero eccentricity P_o has been introduced in section 22.4.2.3:

$$P_o = 0.85 f'_c (A_g - A_{st} - A_{pd}) + f_y A_{st} - (f_{se} - 0.003 E_p) A_{pt} \quad (22.4.2.3)$$

where

A_{st} = total area of nonprestressed longitudinal reinforcement, including bars or steel shapes and excluding prestressing reinforcement

A_{pd} = total area occupied by duct, sheathing, and prestressing reinforcement

A_{pt} = total area of prestressing reinforcement

f_{se} = effective stress in prestressing reinforcement after allowance for all prestress losses

E_p = modulus of elasticity of prestressing reinforcement

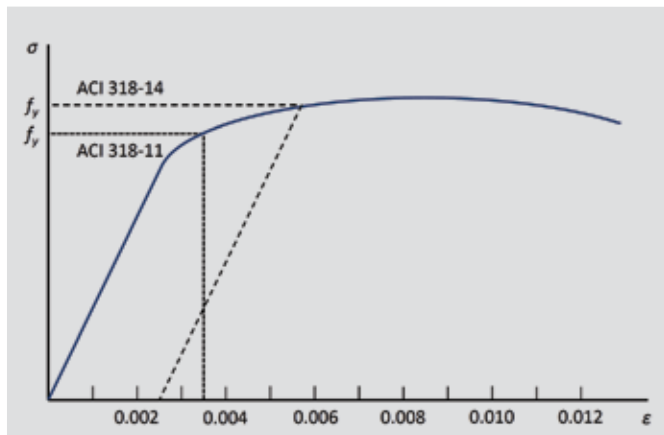

Figure 16. Definition of yield strength of high-strength reinforcement. Note: f_y = specified yield strength for nonprestressed reinforcement; ϵ = strain in reinforcement; σ = stress in reinforcement.

The value of f_{se} is required to be at least $0.003 E_p$. For grouted, posttensioned tendons, it is permitted to assume A_{pd} equals A_{pt} .

- ACI 318-14 has also added a new section 22.4.3.1, which requires that the nominal axial tensile strength of a nonprestressed, composite, or prestressed member P_{nt} not be taken greater than the maximum nominal axial tensile strength of member $P_{nt,max}$ calculated by the following equation:

$$P_{nt,max} = f_y A_{st} + (f_{se} + \Delta f_p) A_{pt} \quad (22.4.3.1)$$

where

Δf_p = increase in stress in prestressing reinforcement due to factored loads

$$(f_{se} + \Delta f_p) \leq f_{py}$$

A_{pt} = zero for nonprestressed members

- In ACI 318-11, the two-way shear strength of a slab-column connection that is subjected to concentric axial load only was expressed in terms of force (nominal shear strength V_n , nominal shear strength provided by concrete V_c , nominal shear strength provided by shear reinforcement V_s), while the two-way shear strength of a slab-column connection that is subjected to axial load and moment was expressed in terms of stress (equivalent concrete stress corresponding to nominal two-way shear strength of slab or footing v_n , stress corresponding to nominal two-way shear strength provided by concrete v_c , and equivalent concrete stress corresponding to nominal two-way shear strength provided by reinforcement v_s). In ACI 318-14, the two-way shear provisions are all expressed in terms of stress.
- For typical cruciform shear reinforcement layouts, ACI 318-11 commentary sections R11.11.3 and

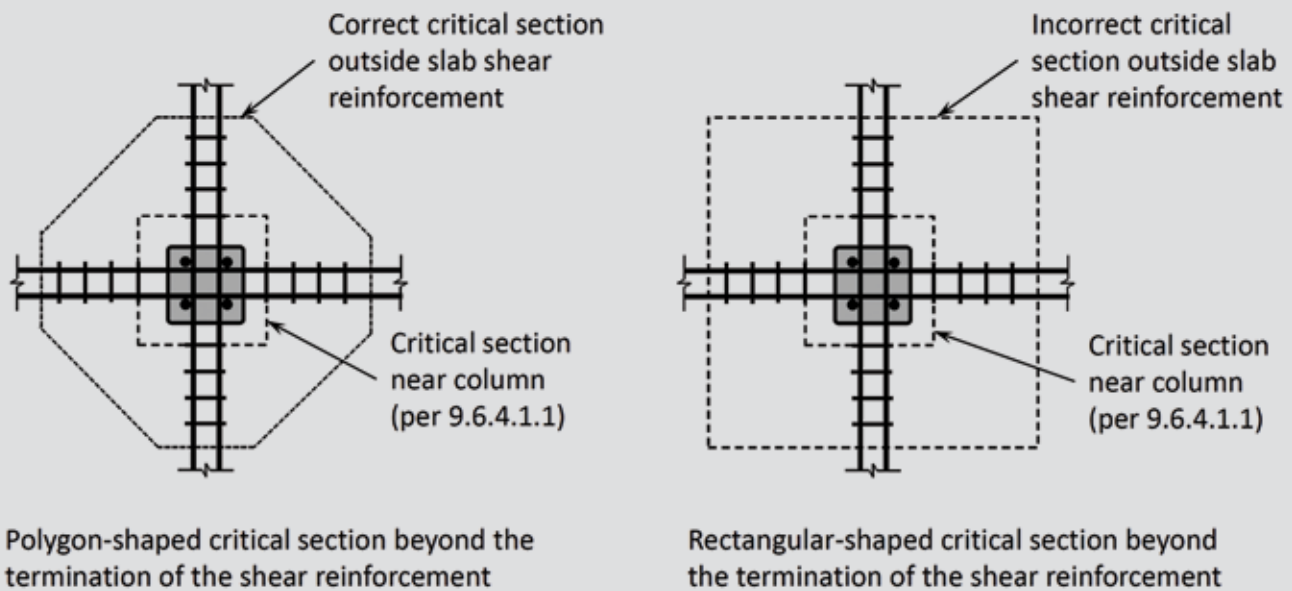

Figure 17. Critical section for two-way shear around discontinued punching shear reinforcement.

R11.11.5 recommend outer critical sections with diagonal segments in the open quadrants of the cruciform, yielding a polygon for the critical section rather than the rectangle permitted for the critical section nearest the column (**Fig. 17**). However, it came to the attention of ACI Committee 318 that a widely distributed commercial concrete design program uses a straight-sided critical section beyond the termination of the shear reinforcement (**Fig. 17**).

The polygon-shaped critical section corresponds to the minimum perimeter of the outer critical section b_o . Using a rectangular outer critical section with cruciform reinforcement layouts can result in a 30% increase in calculated factored shear strength or shear reinforcement being discontinued too close to the column.

Section 22.6.4.2, therefore, now reads: “For two-way members reinforced with headed shear reinforcement or single- or multi-leg stirrups, a critical section with perimeter b_o located $d/2$ beyond the outermost peripheral line of shear reinforcement shall also be considered. The shape of this critical section shall be a polygon selected to minimize b_o .” d is distance from extreme compression fiber to centroid of longitudinal tension reinforcement.

The underlined sentence is newly added to ACI 318-14 to provide clarification.

Chapter 25: Reinforcement Details

The two changes shown in **Table 7** (part of ACI 318-14 Table 25.3.2) are made to eliminate the difference between the required tail extension of a 90-degree or 135-degree

standard hook ($6d_b$ in ACI 318-11) and that of a seismic hook ($6d_b$, subject to a minimum of 3 in. [75 mm]).

The provisions in ACI 318-11 section 12.14.3.5 and associated commentary allowed the use of mechanical or welded splices with strength lower than 125% of the specified yield strength f_y of the spliced reinforcing bars provided that such splices were used on no. 5 (16M) and smaller bars and that the splices met other requirements, such as staggering, outlined in ACI 318-11 section 12.15.5. These provisions were originally written to accommodate a mechanical splice product, which delivered such lower performance, and for welds of lower strength. Due to the development of new mechanical splices, the need for such a category of splice for bar sizes no. 5 and smaller no longer exists and the provisions and commentary have therefore been deleted from ACI 318-14.

ACI 318-11 referred to the 17th edition of the American Association of State Highway and Transportation Officials (AASHTO) *Standard Specification for Highway Bridges*³⁸ for the design of local zone reinforcement in posttensioned anchorage zones. However, AASHTO is no longer updating the *Standard Specification for Highway Bridges*. Therefore, in section 25.9.4.3.1, reference is now made to the *AASHTO LRFD Bridge Design Specifications*.³⁹

Chapter 26: Construction Documents and Inspection

There was no direct counterpart to chapter 26 in ACI 318-11. ACI Committee 318 has concluded that ACI 318 is really written to the engineer, not the contractor. This means that all construction requirements—all construction-related information that the engineer needs

Table 7. Minimum inside bend diameters and standard hook geometry for stirrups, ties, and hoops

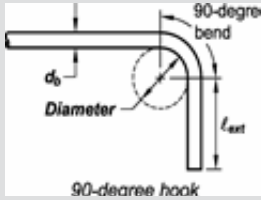
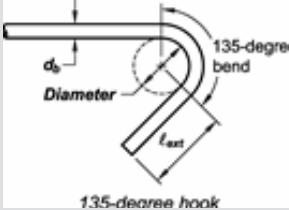
Type of standard hook	Bar size	Minimum inside bend diameter, in.	Straight extension l_{ext} in.	Type of standard hook
90-degree hook	No. 3 to 5	$4d_b$	Greater of $6d_b$ and 3 in.	 <p>90-degree hook</p>
	No. 6 to 8	$6d_b$	$12d_b$	
135-degree hook	No. 3 to 5	$4d_b$	Greater of $6d_b$ and 3 in.	 <p>135-degree hook</p>
	No. 6 to 8	$6d_b$		

Source: Data from ACI 318-14 Table 25.3.2

Note: d_b = nominal diameter of bar, wire, or prestressing strand; l_{ext} = extension of hook beyond 90-, 135-, or 180-degree bend. 1 in. = 25.4 mm; no. 3 = 10M; no. 4 = 13M; no. 5 = 16M; no. 6 = 19M; no. 7 = 22M; no. 8 = 25M.

to convey to the contractor—must be communicated on the construction documents: the drawings or the specifications. In ACI 318-11, construction requirements were often located with the design requirements. In ACI 318-14, all construction requirements are gathered together in chapter 26. The construction requirements are designated as either design information or compliance requirements. In addition, inspection requirements for concrete construction are imported from chapter 17 of the 2015 IBC. ACI Committee 318 would like inspection requirements to be housed in the standard and referenced from chapter 17 of the IBC. The plan is to have these deleted from editions of the IBC subsequent to the 2015 edition. Inspection requirements for structural steel and masonry have already been dropped from chapter 17 of the IBC in favor of references to AISC 360⁴⁰ and the MSJC code,⁴¹ respectively.

The first paragraph of the commentary to chapter 26 gives a good idea of what the chapter is about:

This chapter establishes the minimum requirements for information that must be included in the construction documents as applicable to the project. The requirements include information developed in the structural design that must be conveyed to the contractor, provisions directing the contractor on required quality, and inspection requirements to verify compliance with the construction documents. In previous editions of the Code through 2011, these provisions were located throughout the document. Starting with the 2014 edition, with the exception of Chapter 17, all provisions relating to construction have been gathered into this chapter for use by the licensed design professional. Construction and inspection-related provisions associated with anchors are in Chapter 17 and are called out

within Sections 26.7 and 26.13, as appropriate.

Ned Cleland says that “When the Structural Engineer of Record (SER), as the Owner’s agent, provides only limited services on a project and the design of the system, connections and components is delegated to the precast concrete subcontractor, there appears to be a large gap in the construction documents as envisioned in Chapter 26. ... there is a liability exposure of the SER who does not provide the design information, compliance requirements or inspection requirements on construction drawings because they have little or no knowledge as to the design of the precast/prestressed concrete.”⁴²

There are some substantive changes made to the ACI 318-11 provisions covered in chapter 26:

- In ACI 318-11 section 3.5.1, “Discontinuous deformed steel fibers shall be permitted only for resisting shear under conditions specified in 11.4.6.1(f)” has been interpreted to restrict other applications in which discontinuous deformed steel fibers could potentially be used. The intent of the wording was not to exclude the use of discontinuous deformed steel fibers. The wording has been improved to indicate that ACI 318-14 only addresses the use of deformed steel fibers for shear. Other applications are not prohibited but rather fall under ACI 318-14 section 1.4.
- ACI 318-11 sections 5.3, “Proportioning on the Basis of Field Experience or Trial Mixtures, or Both;” 5.4, “Proportioning without Field Experience or Trial Mixtures;” and 5.5, “Average Compressive Strength Reduction,” contained prescriptive requirements for mixture proportioning. These requirements are no

longer found in ACI 318-14. Instead, ACI 301-10, *Specifications for Structural Concrete*,⁴³ is referenced from section 26.4.3.

The reason for the removals is that many concrete producers are capable of using their quality control processes to develop appropriate mixtures without following the prescriptive procedures.

The prescriptive requirements on mixture proportioning were directed to the contractor. ACI 301 is the proper document for them. ACI 318 need only provide the acceptance criteria for the concrete, which are now given in section 26.4.2.

Acknowledgments

Significant help with this paper from Pro Dasgupta and Ali Hajjhashemi of S. K. Ghosh Associates Inc. is gratefully acknowledged.

References

1. ACI (American Concrete Institute) Committee 318. 2014. *Building Code Requirements for Structural Concrete (ACI 318-14) and Commentary (ACI 318R-14)*. Farmington Hills, MI: ACI.
2. ICC (International Code Council). 2015. *International Building Code*. Washington, DC: ICC.
3. ACI (American Concrete Institute) Committee 318. 2011. *Building Code Requirements for Structural Concrete (ACI 318-11) and Commentary (ACI 318R-11)*. Farmington Hills, MI: ACI.
4. ACI (American Concrete Institute) Committee 318. 1971. *Building Code Requirements for Structural Concrete (ACI 318-71) and Commentary (ACI 318R-71)*. Detroit, MI: ACI.
5. ACI (American Concrete Institute) Committee 318. 2005. *Building Code Requirements for Structural Concrete (ACI 318-05) and Commentary (ACI 318R-05)*. Farmington Hills, MI: ACI.
6. ACI (American Concrete Institute) Committee 318. 2008. *Building Code Requirements for Structural Concrete (ACI 318-08) and Commentary (ACI 318R-08)*. Farmington Hills, MI: ACI.
7. Kopczyński, C. 2014. "Revised Structural Concrete 'Cookbook' Will Follow a Simpler Recipe." *Seattle Daily Journal of Commerce*, May 9.
8. ACI Committee 318. 2014. *Building Code Requirements for Concrete Thin Shells (ACI 318.2-14) and Commentary (ACI 318.2R-14)*. Farmington Hills, MI: ACI.
9. ASTM Subcommittee A01.13. 2014. *Standard Test Methods and Definitions for Mechanical Testing of Steel Products*. ASTM A370-14. West Conshohocken, PA: ASTM International.
10. ASTM Subcommittee A01.09. 2013. *Standard Specification for Cold-Formed Welded Carbon Steel Hollow Structural Sections (HSS)*. ASTM A1085-13. West Conshohocken, PA: ASTM International.
11. ASTM Subcommittee C09.60. 2014. *Standard Test Method for Air Content of Freshly Mixed Concrete by the Volumetric Method*. ASTM C173/C173M-14. West Conshohocken, PA: ASTM International.
12. ASTM Subcommittee C09.23. 2011. *Standard Specification for Admixtures to Inhibit Chloride-Induced Corrosion of Reinforcing Steel in Concrete*. ASTM C1582/C1582M-11. West Conshohocken, PA: ASTM International.
13. ASTM Subcommittee C01.27. 2008. *Standard Test Method for Compressive Strength of Hydraulic Cement Mortars (Using 2-in. or [50-mm] Cube Specimens)*. ASTM C109/C109M-08. West Conshohocken, PA: ASTM International.
14. ASTM Subcommittee C09.61. 2007. *Standard Practice for Making and Curing Concrete Test Specimens in the Laboratory*. ASTM C192/C192M-07. West Conshohocken, PA: ASTM International.
15. ASCE (American Society of Civil Engineers). 1993. *Minimum Design Loads For Buildings and Other Structures*. ASCE 7-93. New York, NY: ASCE.
16. Lucier, G., C. Walter, S. Rizkalla, P. Zia, and G. Klein. 2011. "Development of a Rational Design Methodology for Precast Concrete Slender Spandrel Beams: Part 1, Experimental Results." *PCI Journal* 56 (2): 88–112.
17. Lucier, G., C. Walter, S. Rizkalla, P. Zia, and G. Klein. 2011. "Development of a Rational Design Methodology for Precast Concrete Slender Spandrel Beams: Part 2, Analysis and Design Guidelines." *PCI Journal* 56 (4): 106–133.
18. SEI (Structural Engineering Institute). 2010. *Minimum Design Loads for Buildings and Other Structures*. ASCE 7-10. Reston, VA: ASCE.
19. CSA (Canadian Standards Association). 2014. *Design of Concrete Structures*. CSA A23.3-14. Etobicoke, ON, Canada: CSA.

20. Standards New Zealand. 2006. *Concrete Structures Standard*. NZS 3101:Part 1:2006. Wellington, New Zealand: Standards New Zealand.
21. Standards New Zealand. 2006. *Concrete Structures Standard – Commentary*. NZS 3101:Part 2:2006. Wellington, New Zealand: Standards New Zealand.
22. Mander, J. B., M. J. N. Priestley, and R. Park. 1988. “Theoretical Stress-Strain Model for Confined Concrete.” *Journal of Structural Engineering* 114 (8): 1804–1825.
23. ACI-ASCE Committee 352. 2002. *Recommendations for Design of Beam-Column Connections in Monolithic Reinforced Concrete Structures*. Farmington Hills, MI: ACI.
24. Kang, T. H.-K., M. Shin, N. Mitra, and J. F. Bonacci. 2009. “Seismic Design of Reinforced Concrete Beam-Column Joints with Headed Bars.” *ACI Structural Journal* 106 (6): 868–877.
25. EERI (Earthquake Engineering Research Institute). 2012. “2010 Maule, Chile, Earthquake Special Issue.” *Earthquake Spectra* 28 (S1). Oakland, CA: EERI.
26. Canterbury Earthquakes Royal Commission. 2012. *Final Report*. 3 parts. Wellington, New Zealand: Ministry of Business, Innovation, and Employment. <http://canterbury.royalcommission.govt.nz/Commission-Reports/>.
27. Tuna, Z., S. Gavridou, J. W. Wallace, T. Nagae, and T. Matsumori. 2012. “2010 E-Defense Four-Story Reinforced Concrete and Posttensioned Buildings—Preliminary Comparative Study of Experimental and Analytical Results.” Paper presented at the 15th World Conference on Earthquake Engineering, Lisbon, Portugal, September 2012.
28. Thomsen IV, J. H., and J. W. Wallace. 2004. “Displacement-Based Design of Slender Reinforced Concrete Structural Walls—Experimental Verification.” *Journal of Structural Engineering* 130 (4): 618–630.
29. ICBO (International Conference of Building Officials). 1997. *Uniform Building Code*. Whittier, CA: ICBO.
30. NIST (National Institute of Standards and Technology). 2014. *Recommendations for Seismic Design of Reinforced Concrete Wall Buildings Based on Studies of the 2010 Maule, Chile Earthquake*. NIST GCR 14-917-25: Task Order 21 (ATC-94 Project). Washington, DC: NIST.
31. ASTM Subcommittee C01.10. 2015. *Standard Practice for Sampling Freshly Mixed Concrete*. ASTM C595/C595M-15. West Conshohocken, PA: ASTM International.
32. ASTM Subcommittee C09.60. 2014. *Standard Practice for Sampling Freshly Mixed Concrete*. ASTM C172/C172M-14a. West Conshohocken, PA: ASTM International.
33. ASTM Subcommittee C09.60. 2014. *Standard Test Method for Air Content of Freshly Mixed Concrete by the Pressure Method*. ASTM C231/C231M-14. West Conshohocken, PA: ASTM International.
34. Paulson, C., S. K. Graham, and J. M. Rautenberg. 2013. *Determination of Yield Strength for Nonprestressed Steel Reinforcement*. Charles Pankow Foundation RGA 04-13, WJE 2013.4171. Pasadena, CA: Wiss, Janney, Elstner Associates Inc.
35. ASTM Subcommittee A01.05. 2015. *Standard Specification for Deformed and Plain Carbon-Steel Bars for Concrete Reinforcement*. ASTM A615/A615M-15. West Conshohocken, PA: ASTM International.
36. ASTM Subcommittee A01.05. 2014. *Standard Specification for Deformed and Plain Low-Alloy Steel Bars for Concrete Reinforcement*. ASTM A706/A706M-14. West Conshohocken, PA: ASTM International.
37. ASTM Subcommittee A01.05. 2015. *Standard Specification for Deformed and Plain Stainless Steel Wire and Welded Wire for Concrete Reinforcement*. ASTM A1022/A1022M-15. West Conshohocken, PA: ASTM International.
38. AASHTO (American Association of State Highway and Transportation Officials). 2002. *Standard Specification for Highway Bridges*. 17th ed. Washington, DC: AASHTO.
39. AASHTO. 2012. *AASHTO LRFD Bridge Design Specifications*. Washington, DC: AASHTO.
40. AISC (American Institute of Steel Construction). 2010. *Specification for Structural Steel Buildings*. ANSI/AISC 360-10. Chicago, IL: AISC.
41. MSJC (Masonry Standards Joint Committee). 2013. *Building Code Requirements and Specification for Masonry Structures*. TMS 402/602, ACI 530/530.1, ASCE 5/6. Longmont, CO: The Masonry Society.
42. Cleland, N. M. 2006. Private correspondence with S. K. Ghosh.
43. ACI Committee 301. 2010. *Specifications for Structural Concrete (ACI 301-10)*. Farmington Hills, MI: ACI.

Notation

a	= depth of equivalent rectangular stress block	C_d	= deflection amplification factor
A_{cb}	= concrete area of shear wall boundary element	C_s	= force in tension reinforcement
A_{ch}	= cross-sectional area of a member measured to the outside edges of transverse reinforcement	d	= distance from extreme compression fiber to centroid of longitudinal tension reinforcement
A_{cv}	= gross area of concrete section bounded by web thickness and length of section in the direction of shear force considered in the case of walls and gross area of concrete section in the case of diaphragms, not to exceed the thickness times the width of the diaphragm	d_b	= nominal diameter of bar, wire, or prestressing strand
A_g	= gross area of concrete section; for a hollow section, A_g is the area of the concrete only and does not include the area of the void(s)	E_p	= modulus of elasticity of prestressing reinforcement
A_{pd}	= total area occupied by duct, sheathing, and prestressing reinforcement	f_c'	= specified compressive strength of concrete
A_{pt}	= total area of prestressing reinforcement	f_{ps}	= stress in prestressing reinforcement at nominal flexural strength
A_{sb}	= area of longitudinal reinforcement in shear wall boundary element	f_{py}	= specified yield strength of prestressing reinforcement
A_{sh}	= total cross-sectional area of transverse reinforcement, including crossties, within spacing s and perpendicular to dimension b_c	f_{se}	= effective stress in prestressing reinforcement after allowance for all prestress losses
A_{st}	= total area of nonprestressed longitudinal reinforcement, including bars or steel shapes and excluding prestressing reinforcement	f_y	= specified yield strength for nonprestressed reinforcement
b	= width of compression face of member	f_{yt}	= specified yield strength of transverse reinforcement
b_c	= cross-sectional dimension of member core measured to the outside edges of the transverse reinforcement composing area A_{sh}	h	= overall thickness, height, or depth of member
b_o	= perimeter of critical section for two-way shear in slabs and footings	h_{beam}	= overall depth of beam
b_t	= width of the part of the cross section that contains the closed stirrups resisting torsion	h_{column}	= overall depth of column
b_w	= web width or diameter of circular section	h_u	= laterally unsupported height at extreme compression fiber of wall or wall pier, equivalent to ℓ_u for compression members
c	= distance from extreme compression fiber to neutral axis	h_w	= height of entire wall from base to top or clear height of wall segment or wall pier considered
C	= externally applied compression force on section	h_x	= maximum center-to-center spacing of longitudinal bars laterally supported by corners of crossties or hoop legs around the perimeter of the column
C_c	= compression concrete force	h_1	= plan dimension of column in one of two orthogonal directions
		h_2	= plan dimension of column in other orthogonal direction
		k	= effective length factor
		k_f	= concrete strength factor

k_n	= confinement effectiveness factor		nal two-way shear strength provided by reinforcement
ℓ_d	= development length in tension of deformed bar, deformed wire, plain and deformed welded-wire reinforcement, or pretensioned strand	V_c	= nominal shear strength provided by concrete
ℓ_{ext}	= extension of hook beyond 90-, 135-, or 180-degree bend	V_n	= nominal shear strength
ℓ_o	= length, measured from joint face along axis of member, over which special transverse reinforcement must be provided	V_s	= nominal shear strength provided by shear reinforcement
ℓ_u	= unsupported length of column or wall	V_u	= factored shear force at section
ℓ_w	= length of entire wall, or length of wall segment or wall pier considered in direction of shear force	w/cm	= water–cementitious materials ratio
M_u	= factored moment at section	x	= cover from center of extreme layer of concentrated flexural reinforcement to extremity of wall
n_l	= number of longitudinal bars around the perimeter of a column core with rectilinear hoops that are laterally supported by the corner of hoops or by seismic hooks; a bundle of bars is counted as a single bar	x_i	= dimension from centerline to centerline of laterally supported longitudinal bars
P_{nt}	= nominal axial tensile strength of member	γ	= distance of line of application of compression concrete force from neutral axis divided by total depth of section
$P_{nt,max}$	= maximum nominal axial tensile strength of member	δ	= maximum out-of-plane deflection
P_o	= nominal axial strength at zero eccentricity	δ_u	= design displacement
P_u	= factored axial force, to be taken as positive for compression and negative for tension	Δf_p	= increase in stress in prestressing reinforcement due to factored loads
s	= center-to-center spacing of items, such as longitudinal reinforcement, transverse reinforcement, tendons, or anchors	ε	= generalized notation for strain
s_b	= spacing of longitudinal reinforcement in shear wall boundary element	ε_{sm}	= strain in reinforcement at the section of maximum deflection
U	= strength of a member or cross section required to resist factored loads or related internal moments and forces in combinations such as those stipulated in ACI 318-14	κ	= ratio of effective depth to total depth of section
T	= externally applied tensile force on section	λ	= modification factor to reflect the reduced mechanical properties of lightweight concrete relative to normalweight concrete of the same compressive strength
v_c	= stress corresponding to nominal two-way shear strength provided by concrete	ξ	= ratio of maximum out-of-plane deflection to member depth
v_n	= equivalent concrete stress corresponding to nominal two-way shear strength of slab or footing	ρ	= A_{sb}/A_{cb}
v_s	= equivalent concrete stress corresponding to nomi-	σ	= generalized notation for stress
		ϕ	= sectional curvature

About the author



Satyendra K. Ghosh, PhD, is the president of S. K. Ghosh Associates Inc. in Palatine, Ill. He is known internationally for his work in earthquake engineering. He has influenced seismic design provisions in the United States for

many years by serving on or chairing numerous committees and advisory panels. He specializes in the analysis and design, including wind- and earthquake-resistant design, of reinforced and prestressed concrete structures. He is active on many national technical committees and is a fellow of the American Society of Civil Engineers (ASCE), Structural Engineering Institute, American Concrete Institute, and PCI. He is a member of ACI Committee 318 and the ASCE 7 Standard Committee.

Abstract

The American Concrete Institute (ACI) has published *Building Code Requirements for Structural Concrete (ACI*

318-14) and Commentary (ACI 318R-14), which has undergone a complete reorganization from its 2011 edition. ACI 318-14 does contain a number of significant technical changes, some of the most important of which are found in chapter 18, Earthquake Resistant Structures. Organizational changes from ACI 318-11 to ACI 318-14 are discussed, as well as significant technical changes in each chapter.

Keywords

ACI 318-14

Review policy

This paper was reviewed in accordance with the Precast/Prestressed Concrete Institute's peer-review process.

Reader comments

Please address reader comments to journal@pci.org or Precast/Prestressed Concrete Institute, c/o PCI Journal, 200 W. Adams St., Suite 2100, Chicago, IL 60606. ¶