

Development of a Precast Concrete Shear-Wall System Requiring Special Code Acceptance



Can Bora

Research Assistant
Department of Civil and
Environmental Engineering
University of Wisconsin
Madison, Wis.

Michael G. Oliva, Ph.D.

Associate Professor
Department of Civil and Environmental
Engineering
University of Wisconsin
Madison, Wis.



Suzanne Dow Nakaki, S.E.

Principal
The Nakaki Bashaw Group Inc.
Irvine, Calif.



Roger Becker, P.E.

Vice President, Precasting Division
Spancrete Industries Inc.
Waukesha, Wis.



Precast, prestressed wall panels comprising thin concrete sections are not commonly used as seismic shear walls. Many engineers and code officials view prestressed materials as nonductile, and the connections between the sandwich wall panels and the foundation may suffer from brittle joint failures. The authors have designed a new load-limiting foundation connection for precast, prestressed panels used as shear walls that prevents the development of excessive uplift forces in the joint. This connection allows precast, prestressed concrete wall panels, such as hollow-core, to act as shear walls in resisting seismic loading without relying on wall ductility or causing an anchorage failure in a thin concrete section of the wall panel (where a connector is located). This unique connector allows the wall system to behave unlike that anticipated by building-code-defined design methods. Building codes require the behavior of new systems to be compared (and proven similar) with that of code-conforming behavior before being used. This paper describes the development and testing of the proposed load-limiting connector and wall system and the wall design approach needed to obtain special building code approval for its use.

Precast concrete walls provide an excellent envelope for low-rise commercial and industrial buildings. They are relatively easy to manufacture, structurally efficient, durable, and attractive. Precast concrete walls are also extremely energy efficient when built with an insulation wythe. In addition, their desirability to the owner and design professionals can be increased tremendously if they provide lateral-load resistance. The focus of this paper is to develop a means for practicing engineers to use precast concrete members with thin cross sections, such as hollow-core panels, as shear walls.

In practice, precast concrete walls have been used for seismic load resistance by designing them to emulate cast-in-place shear walls. This is typically accomplished using ductile vertical reinforcing coupled with splice sleeves or other devices to create continuity across horizontal wall joints because some codes prohibit the use of prestressing across joints to resist seismic load.^{1,2}

Newer systems have recently been developed to take advantage of unbonded, vertical post-tensioning,³⁻⁸ though they may also include spliced reinforcing bars, to develop a strong self-righting wall in response to a seismic event. These newer systems do not emulate normal reinforced concrete shear walls and, as such, have required validation, which is typically accomplished by use of physical experiments and/or analytical models with physical testing to prove their resistance equivalency to a cast-in-place system. The use of vertical post-tensioning, however, may demand thicker walls that have a greater compressive force capacity, special confinement reinforcing at the edges, or special confinement spirals. Vertically post-tensioned walls also need a sufficient cross section to allow splicing of the ductile vertical mild-steel reinforcement.

Many precast concrete components used as exterior walls, such as hollow-core panels, double-tees, and multiwythe insulated panels, do not have thick concrete cross sections. The joining of spliced reinforcing, as needed for emulative design, or the greater compression force capacity and thick-

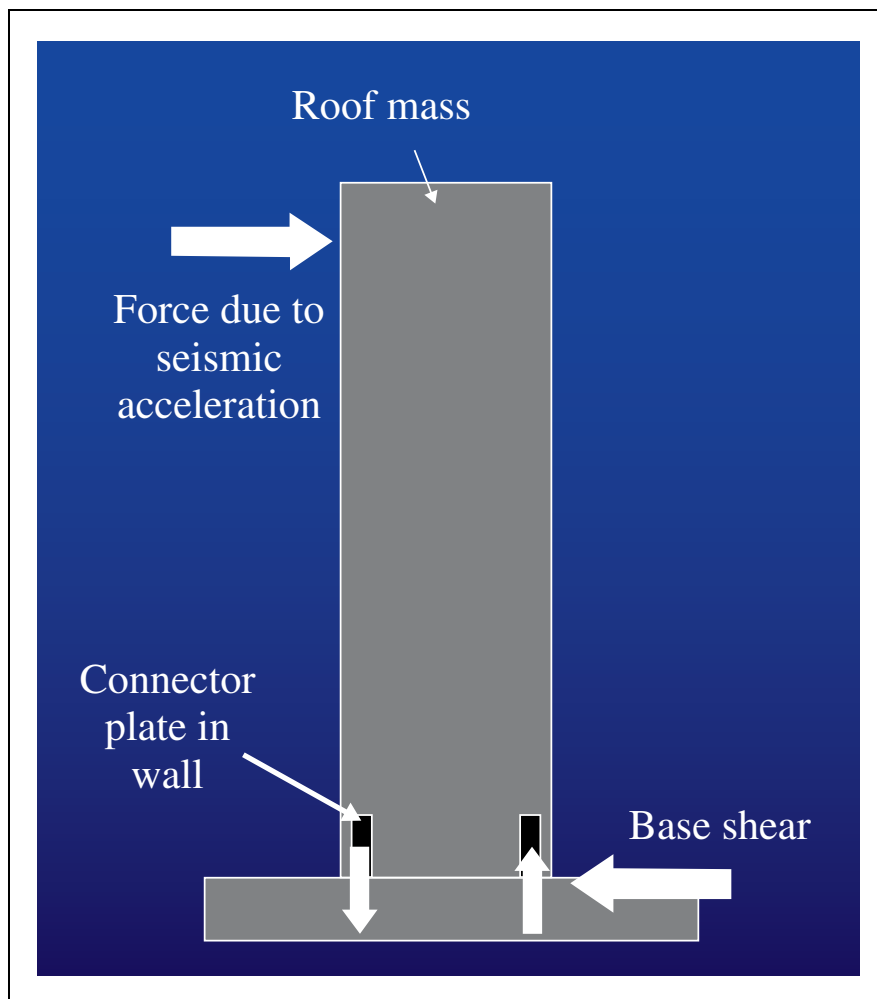

Fig. 1. Force couple and overturning moment.

ness to hold spiral confined concrete with vertical post-tensioning, may not be possible in the thin, precast concrete sections.

In a tall, narrow shear wall (for example, a 30-ft-tall [9 m] \times 8-ft-wide [2.4 m] hollow-core panel), the connection to the foundation has to resist the overturning moments caused by lateral loads. The resistance to overturning moment from lateral seismic loading appears as a vertical force couple at the wall corners as illustrated in **Fig. 1**. In such a system, the moment arm of the lateral force (the height of the wall in a single-story system) is often greater than the wall width. Thus, at one base connection, a large uplift force is created. At the other base corner, a compression force is developed. The capacity of the corner tension connector is limited due to the thin-wall section where the connector plate must be anchored. Tests performed on connections with typical anchorage techniques show that

the connections' tensile capacities may not be sufficient to resist the uplift forces generated from earthquake loads.⁹

The solution for thin-walled members might be to limit the force that the connector could transfer into the wall. If the tension force is limited below the value that would crack off the panel's corner or pull out the anchoring reinforcement, the problem of a thin section failing in a brittle manner could be avoided. Limiting the tension force may limit the lateral-load resistance of a single panel, but the building's total capacity for lateral-load resistance equals the sum of the lateral-load resistances of the numerous wall panels available around the exterior of the building.

The force that the ground applies to the wall system and to the connection anchorage can be limited by the use of special connectors. Investigation of the seismic performance of a variety of connection details shows that friction joints or slotted-bolted (SB) con-

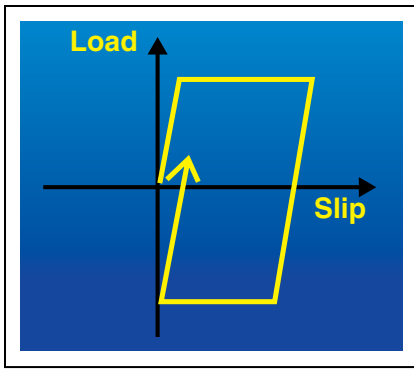

Fig. 2. Ideal load-slip plot.



Fig. 3. Failure of base embed.

nections may provide an efficient way for limiting the shear force applied to the wall system while dissipating substantial earthquake energy.¹⁰⁻¹³ After slip between the wall panel and the foundation starts and the connection's stiffness decreases, the devices can also significantly lengthen the building period to a range where seismic effects may not be as significant.

The remainder of this paper will describe the development of an SB con-

necter system for thin-walled precast concrete panels that allows the panels to resist earthquake lateral load like a shear wall while also acting as an exterior curtain wall. This new connection system is different from typical shear-wall connector systems included in building-code-proposed design procedures. Because a goal in the development of this connection is to obtain code approval, extensive experimental testing combined with analysis and design procedures was required to show that the walls could respond as well as typical reinforced concrete shear walls subjected to earthquake-induced loads.^{14,15} This paper focuses on describing the system components, key experimental tests, and a suggested design method.

OBJECTIVE, SCOPE, AND SOLUTION PROCEDURE

If SB connectors can maintain an elastic-plastic response, as shown in Fig. 2, when subjected to a seismic force, the force passing through a connection can be limited to avoid anchorage failure in thin-wall sections while providing energy dissipation. Our goals were to prove the connector's performance and to create a code-accepted process for designing and using thin-sectioned precast concrete wall elements as seismic-resistant shear walls

using such connections.

While the current focus was on specifically defining a connection for thin-concrete-sectioned wall elements, similar methods could be applicable to any type of precast concrete panel. In developing the seismic-resisting system described here, only a single type of thin precast concrete element, an 8-ft-wide (2.4 m) hollow-core wall panel, was used.

When subject to lateral forces, the bottom connection in a hollow-core panel might fail as shown in Fig. 3. In the figure, a steel connection plate with reinforcing bars or studs welded to its back side is embedded in the top surface of the hollow-core. When lateral load was applied to the plate, the thin-concrete section below the plate, along with the embedded anchorage steel, broke free. The concrete suffered a brittle failure in tension and the reinforcing bar suffered a bond failure.

In other research, adjacent hollow-core wall panels retrofitted with fiber-reinforced polymers (FRPs) adhesively attached to the concrete faces have shown similar failures in steel plate edge connections.¹⁶ These failures might also be expected in other thin-sectioned precast concrete members. This illustrates that hollow-core is emblematic of the general problem of obtaining satisfactory seismic base connections in thin-sectioned precast concrete wall panels.

Other authors have suggested various means of obtaining satisfactory behavior in precast concrete shear-wall systems.⁶ While much attention has been dedicated to achieving wall base connections that can develop a couple to resist overturning in thick walls, as in Fig. 1, consideration must also be directed to transferring the horizontal base shear.^{17,18} Previous studies have developed excellent methods for transforming thick precast concrete panels into shear walls but have neglected thin sections.

One method to reduce the force couple at the base of thin wall panels is to connect adjoining panels, forming a wide wall as in Fig. 4. The wider moment arm at the base of the panel reduces the vertical force components. In many instances, this may be an acceptable solution, and connectors have

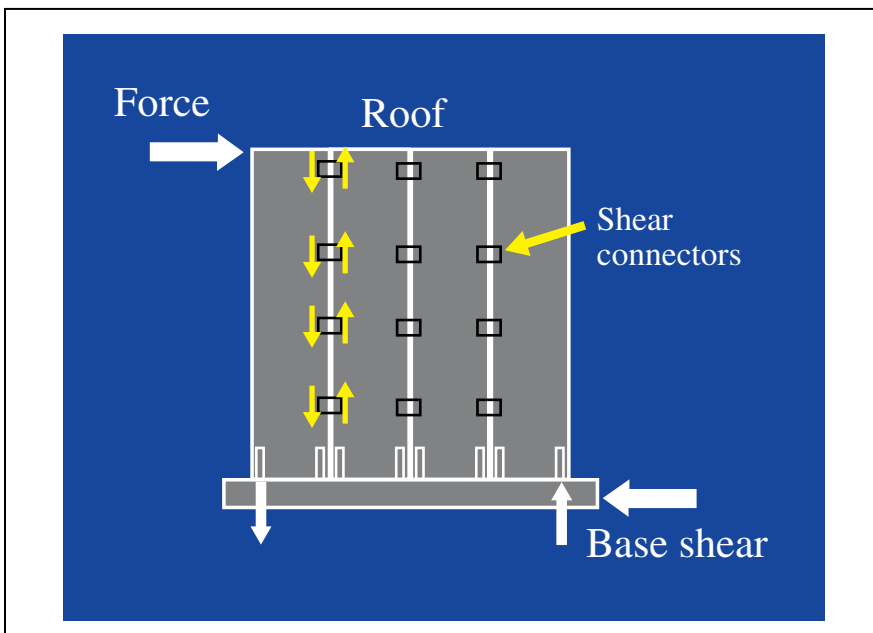

Fig. 4. Joining adjacent panels.

been developed for these locations.^{19,20} As the wall becomes wider, however, the force in the connections between the panels increases. Now the same anchorage problem may exist, but it is located in the connections between adjoining elements. Although successful wall connections have been made in this manner using FRPs, the wet field layup required for use of FRPs is difficult during inclement weather and may not be practical for typical construction.

After considering alternative solutions, the use of a base connection that could limit the force transferred into the wall (to avoid wall or anchorage failure) was chosen for the hollow-core application. Adjoining panels were not connected.

To develop a code-accepted process for designing shear walls composed of the hollow-core panels with SB base connectors, the capacity of the entire proposed wall system needs to be compared with that of code-conforming shear-wall systems, and it must prove to behave equivalent to or better than current systems. The solution method includes identifying all components of the wall that will contribute to the lateral-load-resisting system, defining the behavior and design of each component, and defining the design approach for the entire lateral-load-resisting system. Each of these steps is discussed in the following sections for the hollow-core example. Examination of this problem was pursued by a cooperative venture. Engineers from Spancrete Machinery Corp. and University of Wisconsin researchers developed components and examined component behavior. The Nakaki Bashaw Group led the development of design procedures and the code approval process.

THE PROPOSED SYSTEM: COMPONENTS

Figure 5 shows a schematic sketch of the proposed wall system. The system includes all components required to transfer lateral seismic load between a roof diaphragm and the foundation: the connection to a roof diaphragm (top connection), the wall itself, a compression/shear base connection, and a tension base connection.

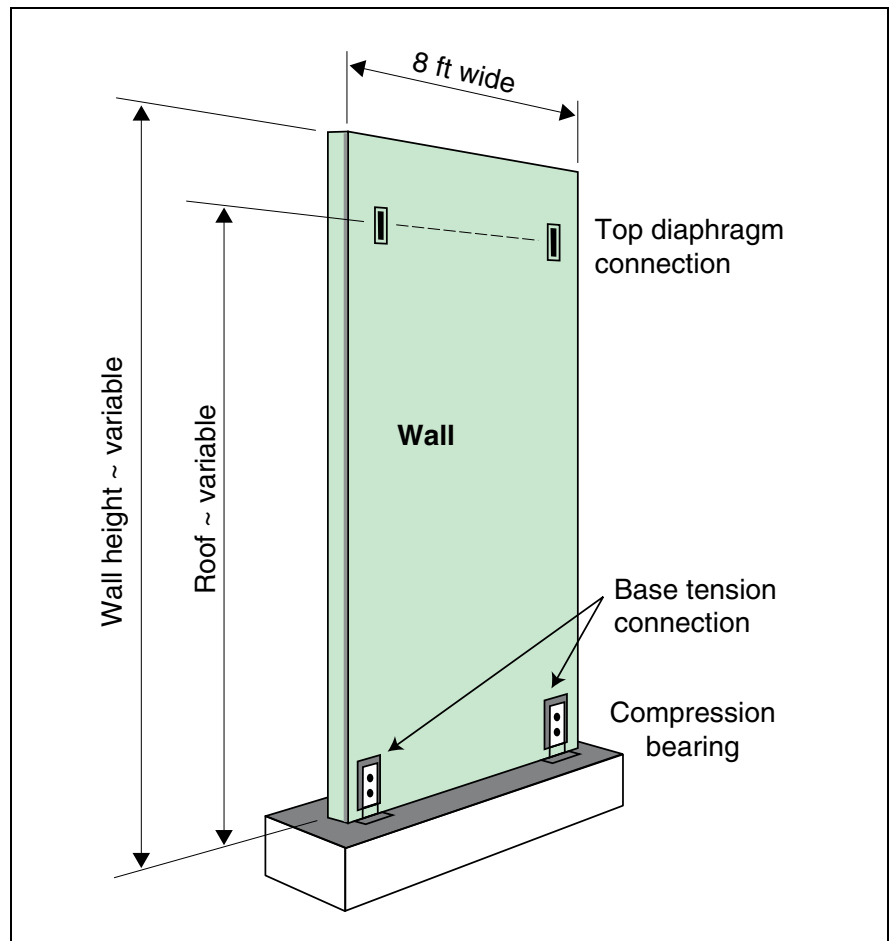

Fig. 5. Components of the proposed system. Note: 1 ft = 0.305 m.

Top Connection

A typical top connection uses two commercially produced slotted connectors, such as Corewall or PSA-type inserts. A Corewall connection to a lightweight steel roof structure is shown in **Fig. 6**, and added anchorage reinforcing to affix the insert to the concrete is shown in **Fig. 7**.



Fig. 6. Corewall attachment to roof.

Wall Panel

The wall is a standard hollow-core panel, 8 ft (2.4 m) wide and 8 in. (200 mm) thick, with the cross section shown in **Fig. 8**. In some instances, the panel may also include an insulation layer or wythe covered by a thin, protective concrete layer. Because these added elements do not contribute to the panel's lateral-load resistance, their presence is irrelevant in shear-wall performance and is ignored here. Prestressing strands, not shown in the figure, are added inside the panel as needed for out-of-plane strength and handling of the wall panel. Note that the core sizes



Fig. 7. Anchorage of slotted insert.

were varied in cross section at the locations of the top and bottom connectors to increase the concrete section and improve anchorage for the connections.

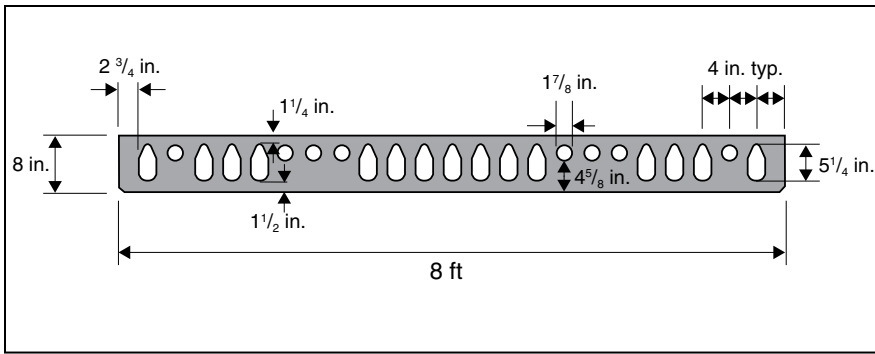

Fig. 8. Wall section. Note: 1 ft = 0.305 m; 1 in. = 25.4 mm.

Compression/Shear Base Connection

The bottom connection is composed of bearing to resist compression and friction (or grout keys) to resist shear. With lateral loading, a tension-compression couple develops, as illustrated in Fig. 1. The corner of the wall must be able to sustain the compression force through bearing. The compression and shear resistance of the bottom joint comes from the bearing

of the wall on the foundation through a packed mortar bedding (which may extend into the panel voids to form keys, if needed). Shear forces are resisted by shear friction and/or shear key action in the compression bearing area between the bottom of the wall and mortar bedding. The size of the bearing area is determined by the combination of vertical gravitational load, the compression component of the overturning moment, and the magnitude of rotation at the base.

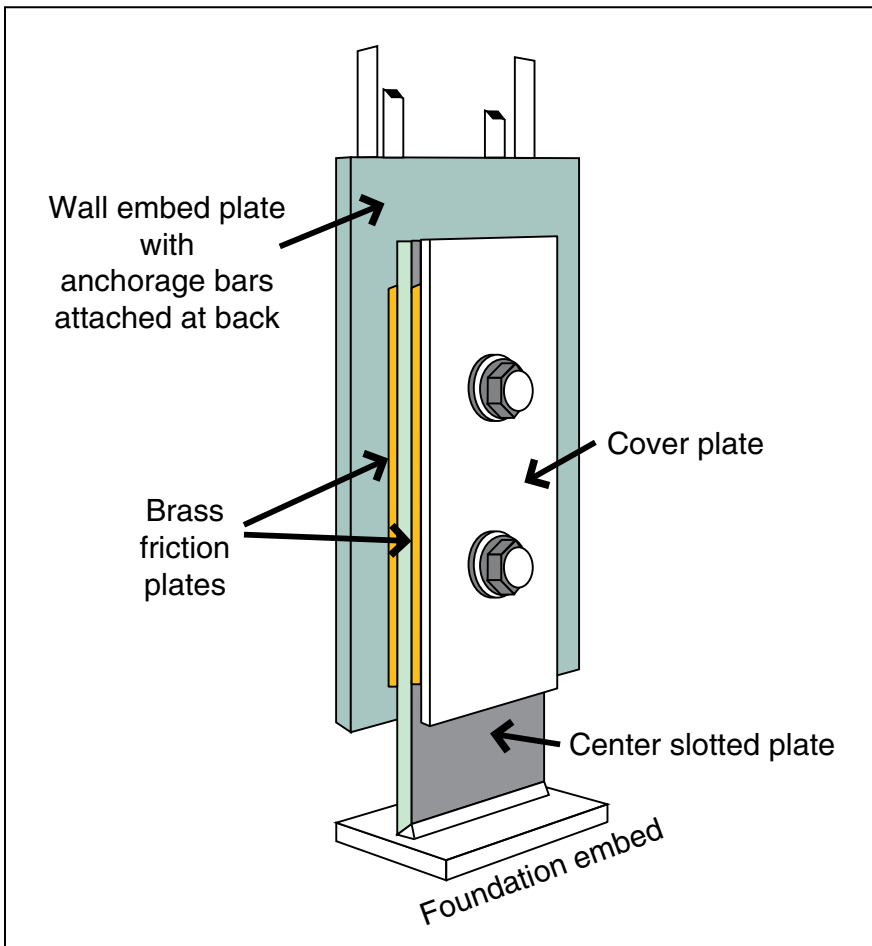

Fig. 9. Diagram of slotted-bolted connector.

Tension Base Connection

A special SB connection is used to resist the tension component of the base force couple. In addition to the SB connection mechanism, an anchorage system for it is required within the wall.

The SB connection system for resisting tension is shown assembled in Fig. 9, and the individual components are shown in Fig. 10. The SB connection is intended to slip and dissipate energy through friction under cyclic loading. Previous experiments conducted on this kind of connection showed that the hysteresis loops of connections with steel-brass friction slip surfaces are similar to those of an ideal rigid-perfectly plastic element.¹³

The SB base slip connection consists of two main outer steel plates sandwiching a third middle steel plate that has slotted holes to accommodate sliding. One of the outer steel plates, at the left in Fig. 10, is embedded in the hollow-core wall panel and has reinforcing bars attached to provide anchorage. The middle slotted plate is welded to a foundation embed plate. The third outer steel plate provides a cover and second friction surface for the connection. Brass plates are placed within the two friction interfaces. The brass is used to provide steadier, more predictable friction behavior than would be seen in steel-to-steel surfaces. The connection is joined using two structural bolts. The bolt tension influences the friction force resistance. Special washers are used to control bolt tension. The bolts are tightened with a calibrated torque wrench to a specific torque, giving a desired bolt tension (or associated joint compression) and friction capacity.

An anchorage system in the wall for the embedded plate is also an essential part of the SB base connection. The type of anchorage depends on the thickness available in the wall panel. In the case of the hollow-core wall, the anchorage detailing is controlled by the slip-form extrusion machine used in the wall manufacturing process. The machine places the zero-slump concrete in three layers and tamps or packs each layer in place individually. The anchorage for the embed plate has to lie within the thickness acceptable for the first layer of tamping. In this case, the anchorage consists of combinations of reinforc-

ing bars and headed studs welded to the plate along with G-stud clips that gripped the prestressing strand behind the plate and kept the plate positioned during concrete placement. The acceptable thickness of the plate is limited to 2.8 in. (710 mm). The back-side of one version of an embed plate is shown in **Fig. 11** with the bottom of the wall on the right side.

BEHAVIOR OF SYSTEM COMPONENTS

The goal of the proposed system might be expanded beyond just the aim of controlling forces applied to the thin sections of special precast concrete wall elements. From a design point of view, it is desirable to identify system components that have the ability to yield versus those that need to be protected from large forces or yielding. As part of this added goal, all parts of the system, except the SB tension base connection, might be designed to remain elastic. This approach can make design quite simple. The SB connection may be designated as the key component to keep the size of loads transferred to the panel below the SB connection's elastic limit and may also be designed to dissipate energy introduced by seismic movement. The behaviors of most of the system components were measured in the laboratory,^{21,22} and they will be examined in this section to identify their behavior, to define elastic force limits and to establish a design approach.

Top Connection

Manufacturers provide strength capacity information with their respective slotted insert connectors. That data may be either in the form of safe working loads (with safety factors such as 3:1) or minimum ultimate strength capacities. Complete behavior information in the form of load versus displacement relationships is generally not available. Connector capacities may also be changed by supplementary anchorage, such as that provided by the reinforcing bar shown attached to the back of the anchor in **Fig. 7**.

The insert shown in **Fig. 6**, without the added reinforcing bar, has a manufacturer's safe working capacity of 4 kip

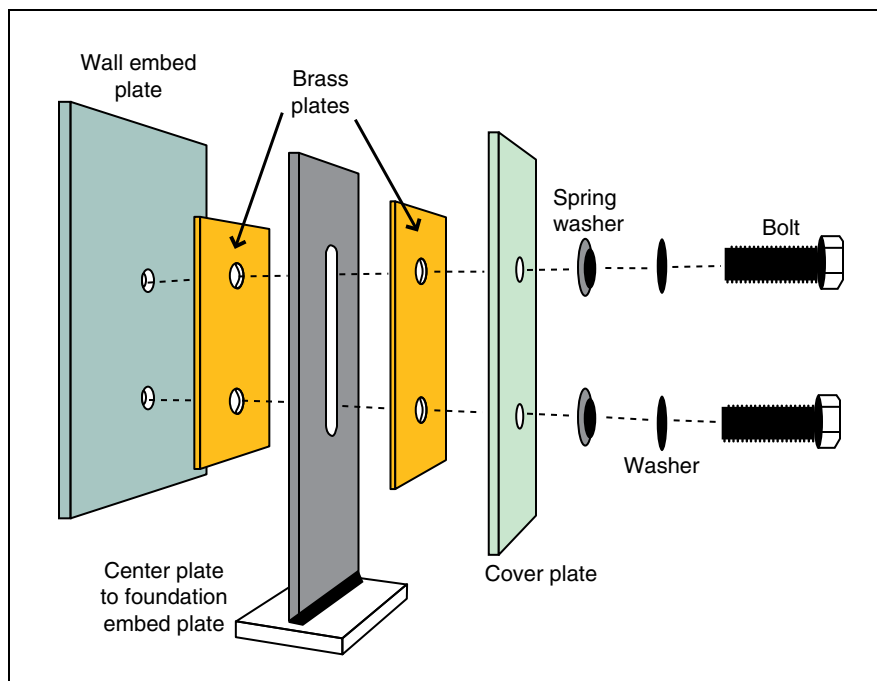

Fig. 10. Components of the slotted-bolted connector system.

(17.8 kN) in tension or shear perpendicular to the slot with a 3:1 safety factor. A tension cone failure calculation would estimate its capacity as approximately 22 kip (98 kN) in tension. Including the effect of the hairpin reinforcing bar, its tension cone breakout capacity might be approximately 31 kip (138 kN). The actual connection capacities were tested in tension and shear.

The capacity of a single connector was measured in three separate out-of-plane tension tests. The flat conical failure plane from a tension test is shown in **Fig. 12**, and the connection behavior is shown in **Fig. 13**. During one of the tests shown in the figure, the displacement measurement became inactive partway through the procedure, but a peak load of 10.9 kip (48 kN) was reached. The initial softening, near 8 kip (36 kN), was coincident with the observation of a small amount of concrete spalling around the visible perimeter of the insert. It is suspected that the bond between the insert surface and the concrete broke at this load. First visible cracking in the panel concrete adjacent to the insert occurred between a load of 10 kip and 12 kip (44 kN to 53 kN), which was also the peak load resisted. The manufacturer's suggested design capacity of 4 kip provided a factor of safety of 2.4 relative to its lowest measured capacity.

Two connectors were attached to a single loaded beam in measuring their horizontal shear capacities to simulate the actual loading of a wall panel with two top inserts. Three identical tests were conducted. The final failure occurred with a popout or spall of the concrete on the far side of the insert, as shown in **Fig. 14**, due to twisting of the insert in the concrete. The connec-



Fig. 11. Back of the base embed plate.



Fig. 12. Slotted connection tension test: flat failure surface.

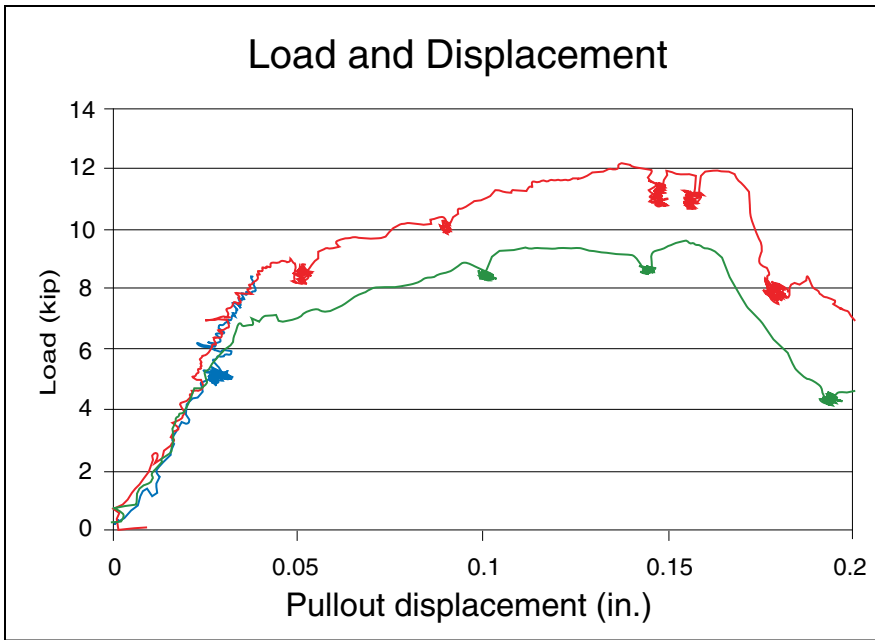

Fig. 13. Slotted-insert pullout test results. Note: 1 kip = 4.45 kN; 1 in. = 25.4 mm.

tor performance is shown in Fig. 15. Initial softening occurred near a load of 10 kip (44 kN) when cracks developed from the strands to the concrete surface (see strands in Fig. 7). The connector appeared to yield and capacity dropped slightly after the circular crack visible in Fig. 14 occurred near 0.8 in. (20 mm) of displacement. Actual shear capacities of 26 kip to 27 kip (115 kN to 120 kN) were reached by the three sets of connectors. The ratio of the measured capacity to the manufacturer's suggested capacity was 6.5, a high factor of safety that may be a

result of the inclusion of the hairpin reinforcing bar.

Wall Panel

Building codes have not encouraged the use of prestressed members for resisting seismic lateral loads due to a perceived lack of ductility in prestressed concrete. While the code objective would be appropriate if the wall panel was expected to develop inelastic behavior, it does not apply to this system. The prestressed wall panel is protected by the limited capacity of the SB base connection. Analytical calcu-



Fig. 14. Slotted connector shear test.

lations that included the effect of prestress were used to define the elastic wall capacity rather than conducting shear and flexural testing.

For flexural design purposes, the wall panel is treated as a beam-column, using the actual cross section to determine its capacity. With no axial load, the cracking moment for a hollow-core panel can be directly calculated. If a lateral load was applied, as in Fig. 1, at a roof height of 34 ft (10.4 m) and the wall moment is limited to the cracking moment, the lateral force capacity limit is equal to the cracking moment divided by the distance to the lateral force.

A dilemma in defining the shear capacity for the wall comes from the two separate approaches in considering its behavior. As a flexural beam-column, the prestressing and axial loads are accounted for in calculating capacity and the flexural force applied is limited by the SB connection. In resisting lateral seismic forces as a shear wall, the wall is considered to be more like structural plain concrete, but shear force is also limited by the SB connection. Wall shear capacity is estimated while ignoring the effect of prestressing and axial load. Determining the appropriate strength reduction factor depends on the type of behavior assumed for the system.

ACI 318²³ allows a shear stress of

$4/3\sqrt{f'_c}$ for plain concrete. The two face wythes of the wall in Fig. 8 could withstand 27 kip (122 kN) of shear at that stress capacity. The webs between the face wythes that form the cores in the hollow-core were ignored in this calculation. In design, a strength reduction factor ϕ must also be selected. This protected wall is considered to be a special reinforced concrete structural wall. The strength reduction factor ϕ

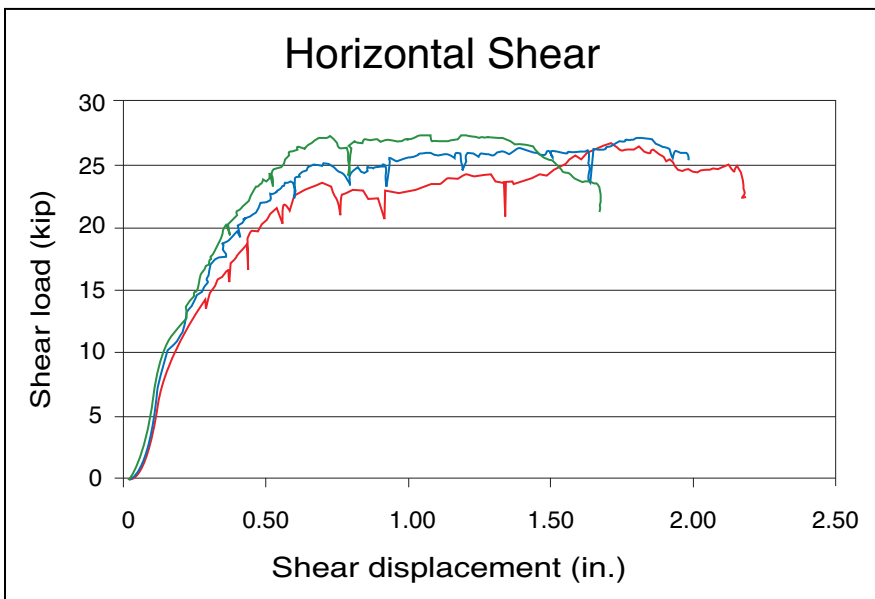

Fig. 15. Slotted-connector performance in shear. Note: 1 kip = 4.45 kN; 1 in. = 25.4 mm.

for shear in reinforced structural walls, where capacity is controlled by flexure, may be taken as 0.85. If the shear strength is less than that corresponding to the nominal flexural strength (unprotected), then Section 9.3.4 of ACI 318 requires that ϕ be taken as 0.60.

Thus, ACI 318 allows the ϕ factor to be increased by 0.85/0.60, or 42%, when it is ensured that the wall will fail first in flexure. The shear ϕ factor for structural plain concrete is 0.55. Because the wall is considered to be plain concrete for shear capacity but is load protected by the SB connectors, to fail first in flexure, an increase in 42% is applied to the 0.55 factor as is done for reinforced walls, resulting in a new strength reduction factor of 0.78. The useable capacity may then be considered to be $0.78\left(4/3\sqrt{f'_c}\right)$, or $1\sqrt{f'_c}$. For design purposes, the shear stress will be limited to $1\sqrt{f'_c}$ to ensure elastic response. Because a modified ϕ factor is already included, it is not necessary to apply an additional capacity reduction factor.

Compression/Shear Base Connection

The right-side corner of the wall in Fig. 1 develops a resultant compression reaction. The total compression is the sum of applied vertical load from a roof, the weight of the wall, and an additional couple component as needed to resist the overturning moment caused by the lateral force.

In this compression region, shear friction is relied on to transfer the seismic base shear.¹⁸ If a roughened surface is provided on the foundation, ACI 318 allows the use of a coefficient of friction equal to 1. Thus, the minimum shear capacity of the wall panel would equal

its weight if it were a non-loadbearing wall. Additional shear capacity will actually exist due to shear keys of dry-pack grout that will form in the voids of the panel at the wall base. These keys will also provide resistance in partially uplifted portions of the wall.

The compression capacity, which could not be analytically predicted, was measured. A series of wall prisms, cut from the bottom corner of a wall such as in Fig. 1, were loaded to measure the useable compression capacity. The prisms were tested in a wider size than the predicted width of the compression region at the wall base due to combined axial load and overturning. Each of the prisms was tested with an eccentric axial load applied in a 1 million lb (454,000 kg) testing machine. The application point of the resultant compression load, 2.5 in. (63 mm) from the wall edge, was selected to mimic the location of the resultant compression force in a wall that is experiencing overturning and uplift at the tension corner. **Figure 16** shows the test setup, and **Fig. 17** shows a typical failure.

The prism test results are summarized in **Table 1**. The compression strength capacity would be expected to vary from that predicted by cylinder tests. Capacity is likely to depend on the configuration of the wall section cores, the development of tension stress fields perpendicular to primary compression, and the lack of transverse confining reinforcement. The results in Table 1 are appropriate for the wall configuration produced. Failure capacities were consistent, and the peak strain at the outside edge of the wall ranged from 0.0014 to 0.0019, with an average of 0.00162, which is about half the maximum strain used in normal strength calculations. Tests with load applied at other eccentricities produced



Fig. 16. Compression test prism with eccentric load.



Fig. 17. Typical failure of compression test prism.

Table 1. Prism Compression Test Results

Prism Test Specimen	Peak Load, kip	Peak Strain	Neutral Axis Location from Edge, in.
Prism 1	220	0.00158	8.7
Prism 2	222	0.00193	8
Prism 3	214	0.00136	7.2

Note: Peak strain is measured at the outside edge of the wall, and the neutral axis is measured from the edge at failure. 1 kip = 4.45 kN; 1 in. = 25 mm.

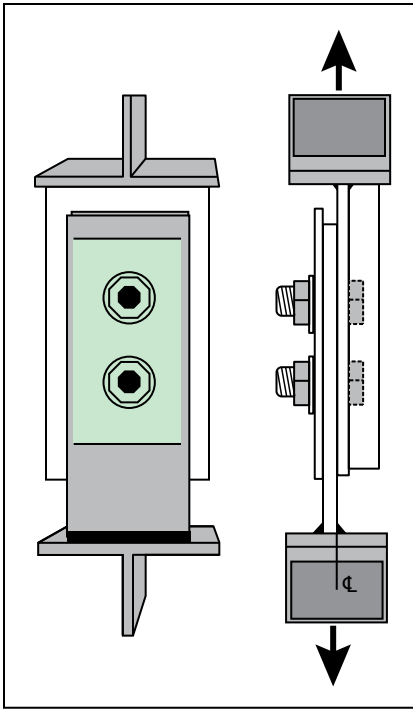

Fig. 18. Schematic of slotted-bolted connector joint test setup.

similar results.

Tension Base Connection

Particular attention was directed at evaluating the performance of the SB connection because it is relied on to control the peak seismic base force applied to the wall. Since this is the only component intended to yield, it needed to be examined under cyclic loading. Fifteen tests were run with various designs for the connection. The testing program was patterned similar to previous research by Grigorian and Popov on connections for diagonal bracing.¹³



Fig. 19. Slotted-bolted connector test assembly in test machine.

Popov used a series of imposed sinusoidal displacement cycles that were intended to mimic the expected displacements that the connector might see during a seismic event. The cycles were at displacement levels of 0.4, 0.7, 1.1, 1.6, 1.1, 0.7, and 0.4 in. (10, 18, 28, 41, 28, 18, and 10 mm).

The current SB connection assemblies were separated from the wall panel and tested alone for convenience. All of the components were noted previously in Fig. 10. The test assembly is shown schematically in Fig. 18 and placed in the test machine in Fig. 19.

A loading pattern similar to Popov's was selected. The maximum acceptable drift in a 36-ft-tall (11 m) wall was used to pick a peak displacement for the connector tests. An uplift amplitude of 1.6

in. (41 mm) corresponds to a design top drift of the wall of nearly 2%. Therefore, a peak displacement of 1.6 in. was selected for these cyclic tests. At a maximum acceptable drift of 3%, for a wall panel that is 8 ft (2.4 m) wide and rocking about a base corner, the uplift would be nearly 2.6 in. (66 mm).

Because the connection is expected to experience the effects of a minor earthquake before a major earthquake occurs, the cyclic testing started at low force levels. Three cycles of tension load were first applied at a level equal to 25% of the expected slip force (6.25 kip [27.8 kN]). They were followed by three more cycles at an amplitude of 50% of the expected slip force (12.5 kip [55.6 kN]). Then the joint was tested at a series of larger tensile displacement levels of 0.28 in. [7 mm], 0.4, 0.7, 1.1, 1.6, 1.1, 0.7, and 0.4 in. (10, 18, 28, 41, 28, 18, and 10 mm) that would induce slip yield displacement. Three cycles were repeated at each displacement level. Upon completion of those tests, the joint was finally subjected to three cycles at a peak tensile displacement of 2.5 in. (64 mm), or nearly 3% wall drift in an 8-ft-wide (2.4 m) panel. The two cyclic loading programs are shown in Fig. 20 and 21.

The joint property of interest was its force-resisting ability; energy dissipation was secondary. Response measured in the connection, plotted in Fig. 22, is near the ideal elastic-perfectly plastic behavior desired. What looks like double yield levels are actually the results of slip occurring, first between the foundation plate and the wall embed plate, followed by slip between the foundation plate and the cover plate at a slightly larger displacement.

The load level at full slip is very near to the target amount of 30 kip (133 kN), and it remains nearly constant with repetitions and at different displacement levels. Force data from four tests on the final selected joint are listed in Table 2.

The specific characteristics exhibited by the connection may be summarized as follows.

- Elastic capacity: The connection developed an initial average tension tie capacity of

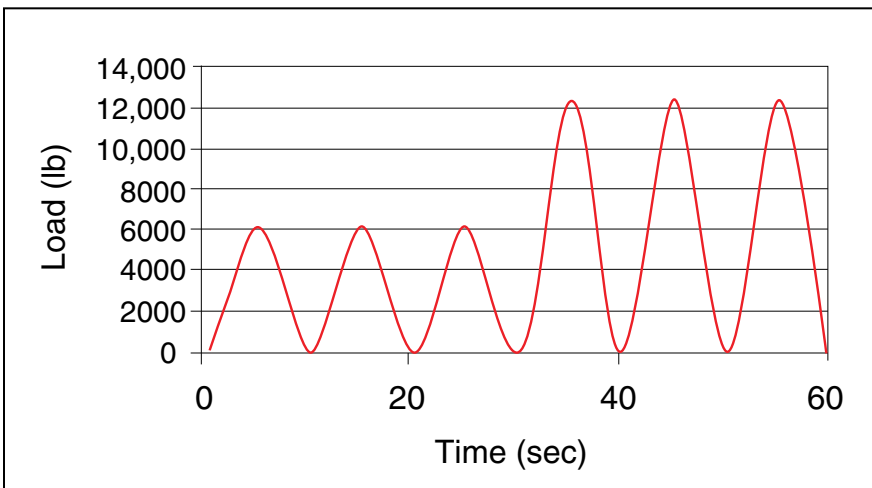

Fig. 20. Initial slotted-bolted connector applied load cycles. Note: 1000 lb = 4.45 kN.

Table 2. Measured Slotted-Bolted Connection Test Results

Peak Measured Slotted-Bolted Connection Values									
Test	Initial Stiffness, kip/in.	Maximum and Minimum Tensile Forces, kip							
		First Cycle		All Cycles		Last Cycle		Last/First, %	
		Max.	Min.	Max.	Min.	Max.	Min.	Max.	Min.
disp04asr	903	34.8	-26.0	36.5	-32.4	30.4	-28.8	87	111
disp05asr	938	34.8	-27.3	34.8	-29.4	27.4	-25.8	79	95
disp06asr	988	30.7	-28.5	34.4	-32.3	30.1	-29.0	98	102
disp07asr	990	33.1	-29.3	36.8	-32.7	31.5	-28.9	95	99

Note: "Last cycle" is taken as the last cycle at 0.4 in. peak displacement; + values are tensile; 1 in. = 25.4 mm; 1 kip = 4.45 kN.

33.3 kip (148 kN) before slip initiated. Variation measured from that average was between +1.5 kip (+6.7 kN) and -2.6 kip (-11.6 kN). The accompanying average elastic stiffness was 955 kip/in. (16,720 kN/mm).

- Peak capacity: The peak uplift force transferred through the connection was measured as 36.8 kip (164 kN). Peak resistance varied 2.4 kip (10.7 kN) among the four cyclic tests. This peak resistance occurred with 1.1 in. (28 mm) of connection displacement.
- Capacity deterioration: Cyclic testing proved that the elastic resistance capacity, before joint slip occurred, decreased slightly under repeated cycling at large displacements (1.1 in. [28 mm] or greater). With 21 cycles of displacement of 0.4 in. (10 mm) and greater, all of the connectors were able to maintain a resistance capacity at slip of 25 kip (111 kN). The actual loss in resistance capacity at slip varied from 2% to 21% after 21 cycles of large displacement.
- Friction damping/energy dissipation: The connector performs as an excellent friction damping system. The energy dissipation remains high through multiple cycles of displacement at a variety of levels from 0.4 in. (10 mm) to 1.6 in. (41 mm) and back to 0.4 in. (10 mm). The connection might be described as a stable elastic-perfectly plastic system.

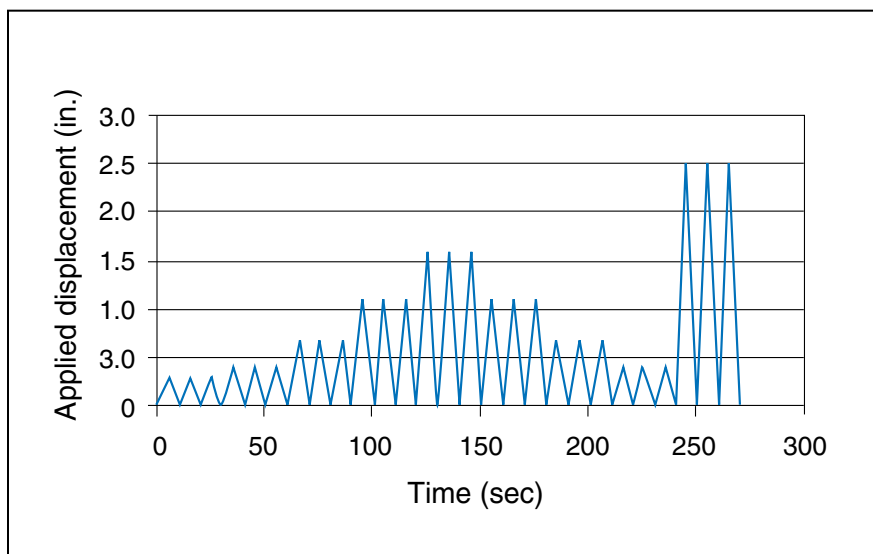

Fig. 21. Applied displacement cycles. Note: 1 in. = 25.4 mm.

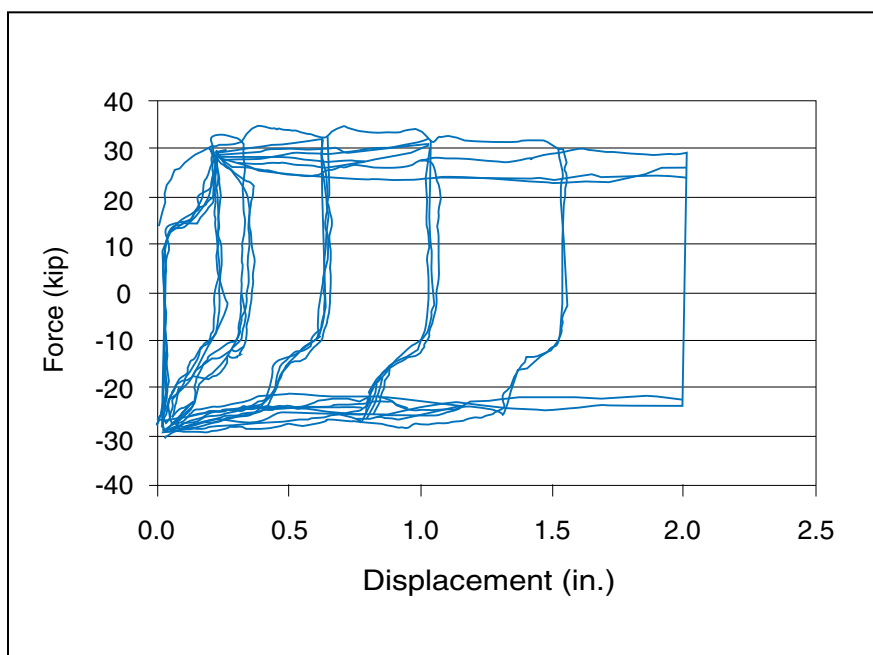

Fig. 22. Load and displacement record from slotted-bolted connector test. Note: 1 kip = 4.45 kN; 1 in. = 25.4 mm.

Table 3: Summary of Component Capacities and Behavior

Component	Tension Pullout Test	Horizontal Shear Test	Vertical Force Test
Top insert	Component yield at 8.3 kip, first crack at failure, 10.8 kip peak, ductile failure	First crack at 8.8 kip, 27.1 kip peak, ductile (for two inserts) failure	—
Wall panel	—	12.7 kip at 34 ft causes flexural crack, 27 kip shear capacity, brittle (analytical prediction) failure	—
Compression base connection	—	—	219 kip capacity with neutral axis at 8 in. from edge, ϵ maximum = 0.00162 brittle failure
Slotted-bolted connector	—	—	Initial slip at 33.3 kip of tension, 35.6 kip capacity, elastoplastic
Base embed	First crack at peak capacity of 11.4 kip, brittle failure	Initial crack at 14 kip 14.9 kip peak, brittle failure	First crack at 27 kip of tension force, 57 kip capacity, limited ductility

Note: 1 kip = 4.45 kN; 1 ft = 0.305 m; 1 in. = 25.4 mm.

Base Embed Plate

The second key portion of the tension base connection is the wall embed plate. As noted previously, anchorage for a large load capacity is difficult to obtain in a thin-walled section. The amount of force transferred can be controlled by changing the torque applied to the SB connection. Because this SB connection is designed to develop a peak force capacity of 36.8 kip (164 kN), the embed plate needs to develop a higher anchorage capacity when resisting the

tension uplift force of the wall. The anchorage provided from a combination of reinforcing bars, headed studs, and G-studs clipped to prestress strand cannot be exactly calculated. A rough approximation might be attempted using an assumed fracture surface.

An initial series of three tests were conducted to determine the uplift resistance capacity of the embed, without anchor studs, at two limit states: cracking and ultimate. A slowly increasing load was applied to the plate through a hydraulic jack system, and the behavior was observed and measured. **Figure 23** shows the resulting failure surface.

The first crack, marked “1” in the figure, occurred at an average load of 21 kip (93 kN). The extension of this crack, marked “2,” developed at an average of 28 kip (124 kN) and represented the tension capacity of the concrete section below the embed plate. Subsequently, the steel anchor bars and strand became more active and continued to increase the embed capacity until it either pulled out with anchorage failure (at 47.5 kip [211 kN]) or the actuator capacity was reached (at 50 kip [222 kN]). The measured behavior of a typical base embed is plotted in **Fig. 24**.

Studs were subsequently added to the back of the embed plate, as shown

in **Fig. 11**, and the anchor reinforcing bars were lengthened to develop a greater ultimate capacity. With these changes, retesting showed that the average cracking load remained near 27 kip (120 kN) and the ultimate capacity could reach 57 kip (254 kN).

The base embed plate was also tested with load applied perpendicular to the wall surface (out of plane) and with shear load applied parallel to the bottom edge of the wall. Three tests were conducted in each configuration. With out-of-plane loading, the first crack and peak load occur simultaneously with an average of 11.4 kip (51 kN). Shear load applied parallel to the wall base and toward the close edge created an initial crack at an average of 14 kip (63 kN). Peak load and failure followed at an average of 14.9 kip (66 kN). For both types of loading, the failure occurred abruptly at peak load with virtually no ductility. Because friction of the mortar joint in the compression bearing region is relied on to resist these loads in the wall system, the embed behavior is not critical as long as the joint static friction capacity is not exceeded.

Summary of Component Capacities and Behavior

The aim of the connection system design is to protect the thin walls of



Fig. 23. Failure surface from base embed test.

precast concrete panels from developing unpredictable or brittle failures, such as pullout. Each of the component capacities is reviewed in **Table 3**. Mechanisms listed as brittle, or failures that are difficult to predict, should be prevented from occurring. As an example, the vertical compression at the base corner of the wall should be controlled so that the strain remains less than 0.0016, the average of limit values listed in Table 1. The component capacity test results came from hollow-core panels with an average 28-day compressive cylinder strength of 7340 psi (50.6 MPa) with a standard deviation of 410 psi (2.8 MPa) in 40 cylinders.

Considering the equilibrium of forces in Fig. 1, there is a direct link between the bottom compression reaction, applied vertical load, SB connector tension force, and the lateral (seismic) load. Thus, controlling the SB connector force can control the base compression reaction component and compression strain. A design philosophy for the wall must be based on these relations.

System Behavior

After completion of the component tests, a full-height, complete wall system was tested and extensive non-linear analyses were conducted to predict building behavior with the wall system under various earthquake motions. These tests and analyses were not required as part of the code approval process and are only briefly described here.

The wall system test was conducted on a full-size, 38-ft-tall (11.6 m) hollow-core wall, but in a horizontal position (**Fig. 25**). The wall base was connected to a fixed abutment using two SB connectors with dry-pack grout under the concrete panel. Lateral displacements were applied to the wall at 36 ft (11 m) from the base, the assumed roof level for a building, by hydraulic jacks attached to the wall with slotted insert connectors. A constant axial load of 20.9 kip (93 kN) was applied at the top of the wall to simulate wall weight (19 kip [84.5 kN]) plus some added dead load.

The first test simulated possible service-level earthquake motion. Before testing, a non-linear analysis of build-

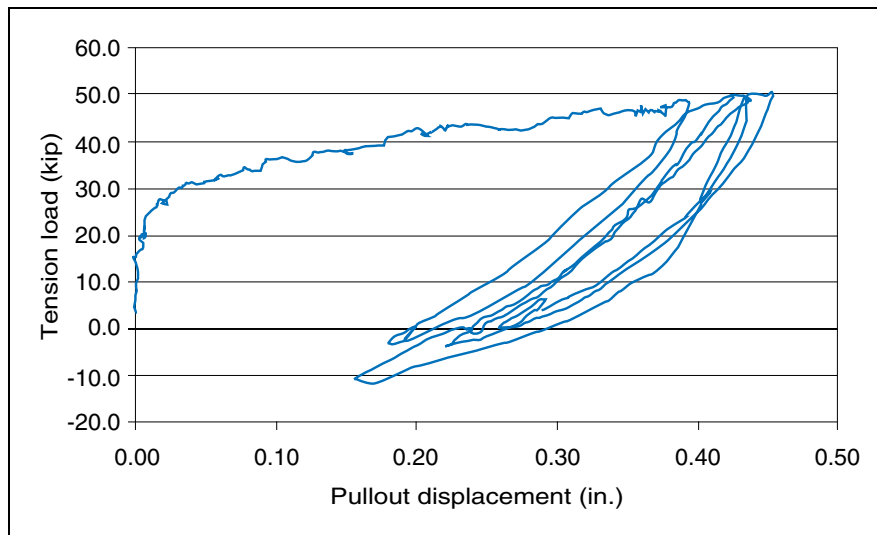

Fig. 24. Embed pullout test with cycling at peak load. Note: 1 kip = 4.45 kN; 1 in. = 25.4 mm.

ing motion was conducted using the 1940 El Centro ground motion record with peak acceleration of 0.33g, where g is the acceleration of gravity. The predicted top-level displacements created by the earthquake were then applied statically to the top of the wall. The SB connectors behaved as expected, and there was virtually no residual uplift at the wall base after the test.

Subsequent tests involved three cycles of reversed cyclic displacement applied to the top of the wall at increasing displacement amplitudes. Finally, the wall was pulled laterally at the top until the base SB connector reached the limit of the slot and force in the connector reached the

level needed to cause anchorage failure between the embed plate and the concrete wall panel.

An extensive series of non-linear seismic response analyses were also conducted at various earthquake amplitudes and differing amounts of wall axial load. The analyses showed that the wall system behaved like a ductile reinforced concrete wall. No significant permanent uplift of the wall developed at the base joint except in some cases with very short walls, strong seismic motion, and no added roof dead load.



Fig. 25. Testing a full-sized wall system in a horizontal position.

DESIGN APPROACH

Because the SB connector has been selected as the preferred location for possible inelastic response and energy dissipation, the overall design approach is to keep all of the other components of the system elastic. Referring to Fig. 26 and the values in Table 3, the following requirements might be applied.

Top Insert Connector (Shear)

With reinforcing bars attached to the back of the anchor (as shown in Fig. 7), the failure mode of the top shear connector is ductile. Therefore, code-proposed safety factors that acknowledge ductile behavior can be used to reduce the allowable load-carrying capacity of the insert, rather than the safety factors that are associated with brittle behavior. However, even though this element is ductile, it should not be relied on to dissipate energy. Capacity design should be used to ensure that the connector behavior is kept elastic.

Top Insert Connector (Tension)

With reinforcing bars attached to the back of the anchor, the failure mode of the top connection in tension is also ductile. The same approach for the design of this connector can be used for tension and shear.

Overtaking Strength of the Base Connector

The base connector not only provides ductile behavior but dissipates energy as it cycles through repeated earthquake motions. This connector should be used to limit loads to the other, less ductile parts of the wall system. The overturning moment ($V \times h$) must be less than the resisting moment ($T \times \text{arm} + [(A + W) \times \text{width}/2]$). Thus, the base shear must be limited to:

$$V \leq \frac{1}{h} \left[T(\text{arm}) + (A + W) \left(\frac{\text{width}}{2} \right) \right]$$

where

- h = height of roof
- T = slip force capacity of the SB connector
- arm = distance between compres-

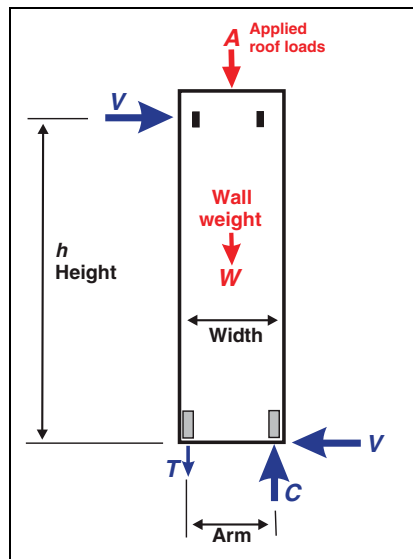

Fig. 26. Design requirements.

- tion and tension couple
- A = applied vertical dead load from roof
- W = weight of the wall panel, as shown in Fig. 26
- width = width of the wall panel

Appropriate safety factors that recognize that this is the ductile element that limits the overall earthquake load to the building should be used.

Wall Shear Strength

The wall shear force should be limited by capacity design to the wall shear strength, modified by an appropriate safety factor. Although it was not tested in this program, the shear failure of a wall panel is likely to be brittle. A design shear stress in the surface wythes of $1\sqrt{f'_c}$ may be used in limiting the wall capacity without applying an added ϕ factor (with f'_c in units of psi).

Wall Base Shear Strength

The shear friction capacity of the grout bed at the base of the wall panel must be greater than the applied shear force. Appropriate safety factors should be applied.

Compression Strain at Wall Base

The base compression force, a combination of vertical load ($A + W$) and the moment resisting couple term T , must be limited in amplitude and applied at a location that will keep concrete strains less than the average com-

pression strain capacity of the panel, or 0.00162. Appropriate safety factors should be applied because this is a brittle failure mode.

Out-of-Plane Base Connector Strength

The out-of-plane loading can be resisted either by the out-of-plane strength of the base connector or by the shear friction capacity of the grout bed. Appropriate safety factors should be applied in either case. Because out-of-plane loading on the grout bed was not tested in this program, a brittle failure mode should be assumed. The out-of-plane strength of the base connector can be calculated using appropriate safety factors depending on the failure mechanism of the component under consideration.

Taking this general approach, a submittal was proposed and subsequently approved by the International Code Council (ICC) Evaluation Services for seismic design of Spancrete hollow-core shear-wall systems.²⁴ The walls are accepted as precast concrete shear-wall systems that comply with the performance requirements of *International Building Code 2003 (IBC 2003)* Chapter 19 for Special Reinforced Concrete Shear Walls.²⁵ With that designation, in combination with the variations in design described previously, seismic requirements may be obtained using the following IBC 2003 criteria:

- $R = 5.5$ (bearing walls)
- $= 6.0$ (nonbearing walls)
- $C_d = 5$
- $\Omega_0 = 2.5$

Details of the design procedure for the tested system can be found in Reference 26.

SUMMARY AND CONCLUSIONS

Precast, prestressed concrete members with thin-concrete sections, often used as exterior curtain walls in commercial and industrial buildings, can act as seismic-resisting shear walls. The primary problem in using these walls for seismic resistance is in developing a satisfactory ductile base connection that can transfer forces from the foundation to the thin-wall panel. A secondary problem is in meeting ex-

isting code criteria for emulation, or in proving the capacity of the system.

Prestressed concrete wall panels can easily be used to resist seismic loads if an alternate ductile mechanism is provided and the prestressing materials are not relied on for ductility. Walls with thin sections can form shear walls if the force transferred into the thin concrete section at the base is limited and brittle anchorage failure is avoided. A ductile SB connection at the wall base is an ideal device to provide ductility and load-limiting control. It has the added advantage of high energy dissipation.

Through a series of experimental tests, the capacities and behavior of a complete precast concrete hollow-core shear-wall system were defined. Those quantities were coupled with a design procedure developed to ensure that the seismic forces introduced into the wall remained lower than the elastic capacities of the wall elements. With the SB base connection as the only yielding element, it was demonstrated that an overall wall response similar to or better than that expected by the *IBC 2003* for special reinforced concrete shear walls could be achieved. ICC Evaluation Services has accepted this performance evidence and the special design procedure as a basis for an accepted method of seismic design.

The principle of using special base connections results in a unique design process. A design base shear could be calculated using typical code methods. The overall base shear capacity of an individual wall panel is then calculated based on a set of rules designed to keep the wall system elastic, except for the yielding base. Then the number of these specially connected seismic walls required may be directly determined from the code-required design-base shear force using an equivalent static load approach.

Although this development of a design approach focused on hollow-core shear walls, a similar approach could be used for other precast concrete wall systems. The test results and design values presented here are based on the unique characteristics of the Spancrete hollow-core panel. This particular Spancrete system is currently in the process of being patented. Results would be different for other hollow-

core or thin-walled panels. A similar test regimen would be required for differing panels, but the same principle of controlling forces could be used.

REFERENCES

1. Freedman, S. 1999. Loadbearing Architectural Precast Concrete Wall Panels. *PCI Journal*, V. 44, No. 5 (September–October): pp. 92–115.
2. PCI Ad Hoc Committee on Precast Walls. 1997. Design for Lateral Force Resistance with Precast Concrete Shear Walls. *PCI Journal*, V. 42, No. 5 (September–October): pp. 44–65.
3. Kurama, Y., R. Sause, S. Pessiki, L. W. Lu, and M. El-Sheikh. 1997. *Seismic Design and Response Evaluation of Unbonded Post-Tensioned Precast Concrete Walls*. PRESSS Report No. 98/03, Lehigh University.
4. Kurama, Y., R. Sause, S. Pessiki, L. W. Lu, and M. El-Sheikh. 1996. *Analytical Modeling and Lateral Load Behavior of Unbonded Post-Tensioned Precast Concrete Walls*. PRESSS Report No. 98/02, Lehigh University.
5. Kurama, Y., S. Pessiki, R. Sause, and L. W. Lu. 1999. Seismic Behavior and Design of Unbonded Post-Tensioned Precast Concrete Walls. *PCI Journal*, V. 44, No. 3 (May–June): pp. 54–71.
6. Kurama, Y. 2002. Hybrid Post-Tensioned Precast Concrete Walls for Use in Seismic Regions. *PCI Journal*, V. 47, No. 5 (September–October): pp. 36–59.
7. Perez, F., S. Pessiki, and R. Sause. 2004. Seismic Design of Unbonded Post-Tensioned Precast Concrete Walls with Vertical Joint Connectors. *PCI Journal*, V. 49, No. 1 (January–February): pp. 58–79.
8. Perez, F., S. Pessiki, and R. Sause. 2004. Lateral Load Behavior of Unbonded Post-Tensioned Precast Concrete Walls with Vertical Joints. *PCI Journal*, V. 49, No. 2 (March–April): pp. 48–65.
9. Private communication. 2003. Spancrete Machinery Corp.
10. Soudki, K., S. Rizkalla, and B. LeBlanc. 1995. Horizontal Connections for Precast Concrete Shear Walls Subjected to Cyclic Deformations Part I: Mild Steel Connections. *PCI Journal*, V. 40, No. 4 (July–August): pp. 78–96.
11. Schultz, A. E., and R. A. Magana. 1996. *Seismic Behavior of Connections in Precast Concrete Walls*. Mete A. Sozen Symposium, Paper SP 162-12, American Concrete Institute (ACI), pp. 273–311.
12. Oliva, M. G., and R. W. Clough. 1985. *Shaking Table Tests of Large-Panel Precast Concrete Building System Assemblages*. EERC Report EERC-83/14, Earthquake Engineering Research Center, University of California–Berkeley.
13. Grigorian, C. E., and E. P. Popov. 1994. *Energy Dissipation with Slotted Bolted Connections*. EERC Report UCB/EERC-94/02, Earthquake Engineering Research Center, University of California–Berkeley.
14. Hawkins, N. M., and S. K. Ghosh. 2003. Proposed Provisional Standard and Commentary: Acceptance Criteria for Special Structural Walls Based on Validation Testing. Report draft, S. K. Ghosh Associates Inc., Northbrook, IL.
15. Hawkins, N., and S. K. Ghosh. 2004. Acceptance Criteria for Special Precast Concrete Structural Walls Based on Validation Testing. *PCI Journal*, V. 49, No. 5 (September–October): pp. 78–93.
16. Pantelides, C. P., V. A. Volnyy, J. Gergely, and L. D. Reaveley. 2003. Seismic Retrofit of Precast Panel Connections with Carbon Fiber Reinforced Polymers. *PCI Journal*, V. 48, No. 1 (January–February): pp. 92–104.
17. Llorente, C. A., J. M. Becker, and E. Kausel. 1981. *Inelastic Behavior of Precast Concrete Shear Walls*. Pub. No. R81-25, Massachusetts Institute of Technology, Cambridge, MA.
18. Soudki, K., J. West, S. Rizkalla, and B. Blackett. 1996. Horizontal Connections for Precast Concrete Shear Wall Panels under Cyclic Shear Loading. *PCI Journal*, V. 41, No. 3 (May–June): pp. 64–81.
19. Hofheins, C., L. Reaveley, and C. Pantelides. 2002. Behavior of Welded Plate Connections in Precast Concrete Panels under Simulated Seismic Loads. *PCI Journal*, V. 47, No. 4 (July–August): pp. 122–133.
20. Schultz, A. E., M. K. Tadros, X. Huo, and R. Magaña. 1994. Seismic Resistance of Vertical Joints in Precast Shear Walls. In *FIP '94 XII Congress May 29–June 2, Washington, D.C.*, V. 1, pp. E23–E27. London, England: Structural Engineers Trading Organisation Ltd.
21. Oliva, M. G., and C. K. Bora. 2003. *Testing of Spancrete Wall Friction Base Connection*. Report 1-03, Structures and Materials Testing Laboratory, University of Wisconsin–Madison.
22. Oliva, M. G., and C. K. Bora. 2003. *Full-Scale Test of Spancrete Wall with Friction Base Connections-Valders Tests*. Research report, University of Wisconsin–Madison.
23. ACI Committee 318. 2002. *Building Code Requirements for Structural*