

Principles and Practices of Stud Welding



Harry A. Chambers
Consultant
Nelson Stud Welding, Inc.
Elyria, Ohio

The embedment properties of stud welded anchors have been the subject of many testing programs worldwide. Currently, design provisions for cast-in-place anchorages are included in the 2000 edition of the International Building Code (IBC 2000), and these will be introduced along with design provisions for post-placed anchors into the 2002 edition of the ACI Building Code (ACI 318-02). In all of the testing programs, performance and failure modes of the as-welded studs with respect to groups, edge conditions, tension, shear, and combined loadings have been the central theme of the reports. Stud welding principles and practices necessary for obtaining consistent stud weld quality and anchorage performance have received little attention. The purpose of this article is to present the fundamental principles of stud welding and implementing practices so that the user may be confident in the ensuing welding results and performance of the finished product.

Electric arc stud welding was invented just prior to World War II and developed out of a necessity to attach wood planking to naval aircraft carriers. Threaded studs could be placed on the exterior side of steel deck plates by using only one welder rather than drilling holes through the plate, a very slow and labor intensive process. Since that

time, the use of studs has increased enormously in the appliance, automotive, and construction industries.

Today, stud welding is widely used in the construction industry. There are many different stud welded products that are commonly used in the manufacture of precast/prestressed components, including threaded, headed, and deformed bars. These products are

welded to steel plates and other shapes that are embedded in precast/prestressed concrete products for structural connections (see Fig. 1).¹

The behavior of these embedments is critical to the performance of each structural element. Because the strength and integrity of the finished structural system is vital to the overall safety of the structure's occupants and the general public, engineers must give full attention to the planning, design, and execution of these connections.

LITERATURE REVIEW

Test results that describe the performance of headed studs and deformed bars made from cold deformed wire as embedments in concrete are available in various publications.²⁻⁶ References 2 and 3 describe the ability of studs to develop full strength welds and discuss the fact that, in some cases, some welds were less than full strength. References 4 and 5 document embedment shear and tension tests of deformed bar anchors where no weld failures occurred. Reference 6 summarizes the results of extensive testing and studies from many sources on the performance of stud welded anchors and other types of anchorage devices.

STUD WELDING FAILURES

When the proper operation of stud welding equipment is combined with good quality control and inspection procedures, full strength welds can be obtained consistently and result in optimal performance of the embedded anchorages. In the author's experience and in discussions with other experts in the stud welding industry, the root causes for weld or stud failures can usually be attributed to one or more of the following factors:

- Unacceptable base plate material or plate surface condition
- Inappropriate weld settings
- Malfunctioning or obsolete equipment
- Little or no formal training for stud welding operators
- Lack of quality control and inspection procedures

This paper addresses these problems by explaining the fundamentals of the

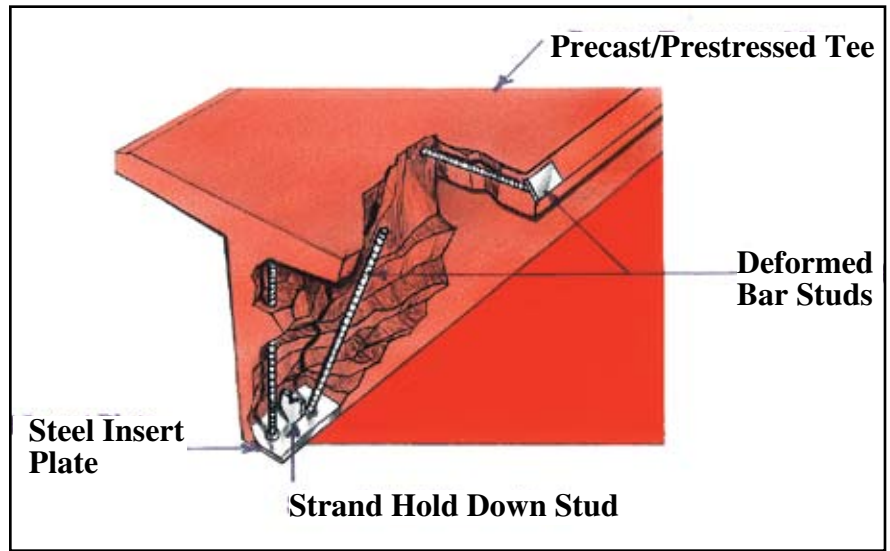

Fig. 1. Typical connection using deformed bar anchor studs in a precast/prestressed concrete tee. Source: Nelson Stud Welding, Inc., Reference 1.

process and highlighting key issues in the assurance of quality in the stud welding process. The first section discusses basic principles, and the second part presents the recommended steps for producing quality stud welds and preventing weld failures.

THE STUD WELDING PROCESS

Electric arc stud welding involves the same electrical, mechanical, and metallurgical principles found in any other arc welding process. In stud

welding, the power source and stud welding control system are set to control the amperage and the arc duration or time. The welding gun has a trigger-activated circuit to initiate the weld and a lifting mechanism to draw the stud away from the base material and initiate the welding arc. The gun includes a stud-holding chuck, two legs, a foot piece, and a ferrule grip to hold the ceramic ferrule (also called an arc shield) (see Fig. 2).

The sequence of operations for making a stud weld is illustrated in

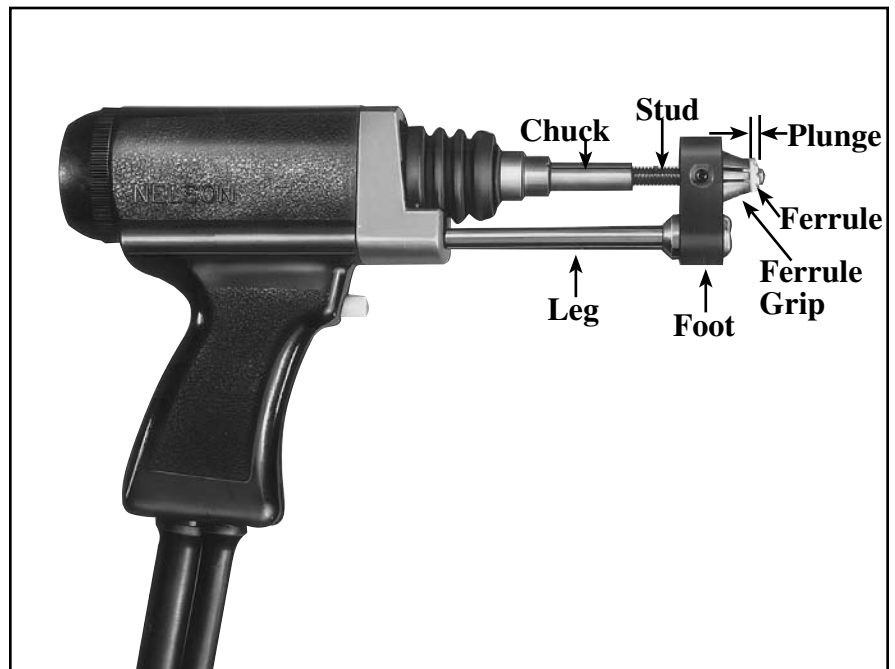

Fig. 2. Stud welding gun. Source: Nelson Stud Welding, Inc.

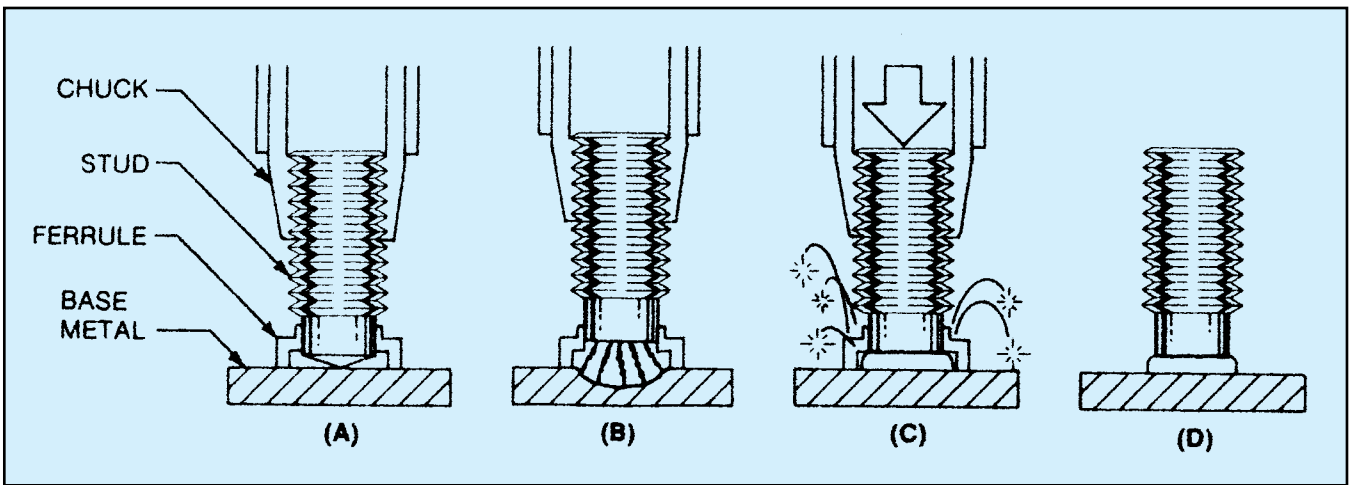

Fig. 3. Sequence of stud welding operations.

- A. A stud and ferrule are loaded into the gun, and the gun properly positioned against the base plate.
- B. The gun is pushed against the base material taking up the plunge, or stud length available for burn off against the gun spring pressure. The trigger button is depressed to start the fully controlled automatic sequence. This sequence consists of initiating the weld current, and lifting the stud to create an arc by energizing the gun solenoid.
- C. The arc duration time is completed and the stud plunged into the molten pool by means of a spring when the gun solenoid is de-energized and turning off the weld current at the end of the weld cycle.
- D. The weld is completed and the gun is lifted off the stud and the ceramic ferrule removed. The stud is inspected for weld quality.

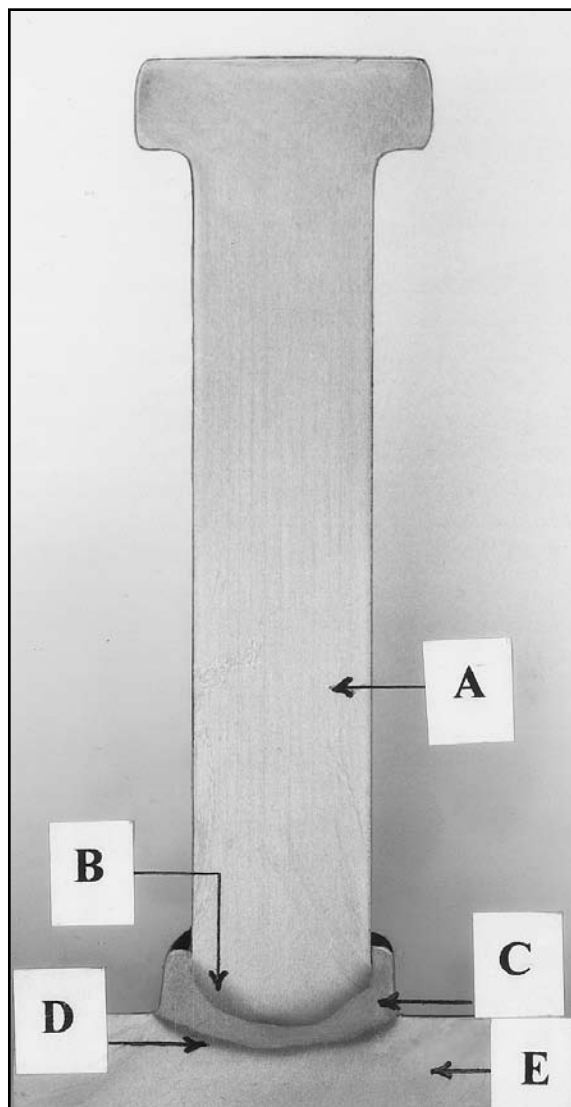

Fig. 4. Typical stud weld cross section. Source: Nelson Stud Welding, Inc.

Weld Zones: (A) Heat-unaffected stud material, (B) Stud heat affected zone (HAZ), (C) Cast zone, (D) Base material HAZ, (E) Heat-unaffected base material.

When performed properly, the stud weld is stronger than both the stud material and base plate material, and failure will occur at the ultimate steel strength in the stud shank or in the base plate, rather than in the weld.

Fig. 3.⁷ The fasteners for electric arc stud welding have a special shape and flux on the end of the stud that is to be welded. This flux initiates and improves starting and stabilizing the welding arc. It also serves to deoxidize the molten weld metal for a sound, low-porosity weld zone to produce a full penetration weld.

The ceramic ferrule confines the weld arc and heat to a specific area of the base material and holds the molten metal in place to provide the uniform weld flash. The term weld flash is used instead of fillet because the weld zone comprises a mixture of melted material from the stud end and expelled from the base plate material, rather than a weld made from a separate filler material that is deposited.

A completed weld cross section is shown in Fig. 4, with the various areas of the weld cross section identified.

STUD MATERIALS

Stud and base plate materials must be compatible with the stud welding process. Suppliers of both materials can provide physical and chemical certification on the products they supply and these should be requested on all orders as part of good quality control recordkeeping. Studs of all styles are available in low carbon steel and

various grades of stainless steel. Commonly used studs in the precast and construction industries are governed by the following American Welding Society (AWS) codes:

Low carbon steel studs: ANSI/AWS D1.1-00, Structural Welding Code—Steel.⁸ Studs are required to meet ASTM A 108⁹ chemical specifications for Grades C-1010 through C-1020 with the mechanical property requirements listed in Table 1. Three stud classifications are identified as follows (see Table 1):

- *Type A* studs are general purpose studs, of any type or size, used for purposes other than embedment or composite design construction. These include 1/4 in. and 3/8 in. (6 and 10 mm) headed anchors.
- *Type B* studs are headed, bent, or some other configuration, 1/2 in. (13 mm) or larger in diameter, used for concrete embedment or as an essential component in composite design construction.
- *Type C* studs are ASTM A 496¹⁰ deformed wires of any diameter, used for concrete embedment purposes.

Stainless steel studs: ANSI/AWS D1.6-99, Structural Welding Code—Stainless Steel.¹¹ Studs are required to meet ASTM A 493¹² or ASTM A 276¹³ chemical specifications for Grades XM-7, 304, 305, 309, 310, or 316, or the low carbon versions of these alloys with the mechanical property requirements listed in Table 2. The properties listed apply to stud Types A and B as described in Table 1. This code does not contain stainless steel Type C, deformed bar studs.

Acceptable base plate materials are listed in ANSI/AWS D1.1, Table 3.1, Groups I and II. These include most of the common low carbon structural steels such as A36, A709, A992, and A516. Both the common carbon steel materials in Table 3.1 of ANSI/AWS D1.1 and the stainless steel materials listed in ANSI/AWS D1.6, Section 7.2.6, that meet ASTM A 276 are acceptable base materials for stainless steel stud welds.

Table 1. Minimum mechanical property requirements for studs.⁸

Property	Type A AWS D1.1	Type B AWS D1.1	Type C ASTM A 496 ⁵
Tensile strength (UTS)	61,000 psi (420 MPa)	65,000 psi (450 MPa)	80,000 psi (552 MPa)
Yield strength (0.2 percent offset)	49,000 psi (340 MPa)	51,000 psi (350 MPa)	Not specified
Yield strength (0.5 percent offset)	Not specified	Not specified	70,000 psi (485 MPa)
Elongation (percent in 2 in.)	17	20	Not specified
Elongation (percent in 5 x diameter)	14	15	Not specified
Percent area reduction	50 percent	50 percent	Not specified

Note: 1 in. = 25.4 mm; 1 psi = 0.006895 MPa.

STUD WELDING EQUIPMENT

Stud welding has been in continuous use for over 60 years. Since the early 1900s, there have been many changes in the equipment used in the process, but the principles remain the same. In the basic process, DC power from a self-contained generator or transformer/rectifier is passed through a stud welding control system. The control system is set at a determined time, voltage, and amperage to initiate the arc, which forms the molten pool. The remaining unmelted stud shank is then plunged into the molten metal pool.

In the early years of stud welding, the power source was separated from the control system. Power came from motor generators, battery banks, and transformer rectifiers. Today, the control system is typically incorporated into the power source, and transformer

Table 2. Minimum mechanical property requirements for stainless steel studs.¹¹

Tensile strength (UTS)	70,000 psi (490 MPa)
Yield strength	35,000 psi
(0.2 percent offset)	(245 MPa)
Elongation (percent in 2 in.)	40

Note: 1 in. = 25.4 mm; 1 psi = 0.006895 MPa.

rectifiers are now the predominant sources of power (see Fig. 5). Systems are available for welding studs with diameters ranging from 1/8 to 1 1/4 in. (3 to 32 mm).

In recent years, the stud welding industry has been transformed from mechanical to solid state welding equipment with closed-loop controls that have contributed significantly to simpler weld setups and better weld quality. These solid state controls provide



Fig. 5. Transformer/rectifier powered stud welding systems. Source: Nelson Stud Welding, Inc.

Table 3. Stud welding setups for mild and stainless steel studs welded to mild and stainless steel base materials.¹⁴

Diameter		Area	Downhand welding					Overhead welding					Vertical welding				
			Amp	Time		Lift	Plunge	Amp	Time		Lift	Plunge	Amp	Time		Lift	Plunge
in.	mm	sq in.		Sec	Cycles				Sec	Cycles				Sec	Cycles		
0.187	4.9	0.0276	300	0.15	8-9	0.062	0.125	300	0.15	8-9	0.062	0.125	300	0.15	8-9	0.062	0.125
0.250	6.4	0.0491	450	0.17	10-12	0.062	0.125	450	0.17	10-12	0.062	0.125	450	0.17	10-12	0.062	0.125
0.213	7.9	0.0767	500	0.25	15	0.062	0.125	500	0.25	15	0.062	0.125	500	0.25	15	0.062	0.125
0.375	9.5	0.1105	550	0.33	20	0.062	0.125	550	0.33	20	0.062	0.125	600	0.33	20	0.062	0.125
0.437	11.1	0.1503	675	0.42	25	0.062	0.125	675	0.42	25	0.062	0.125	750	0.33	20	0.062	0.125
0.500	12.7	0.1964	800	0.55	33	0.062	0.125	800	0.55	33	0.062	0.125	875	0.47	28	0.062	0.125
0.625	15.9	0.3068	1200	0.67	40	0.093	0.187	1200	0.67	40	0.093	0.187	1275	0.60	36	0.062	0.187
0.750	19.1	0.4418	1500	0.84	50-55	0.093	0.187	1500	0.84	50-55	0.093	0.187	1700	0.73	50	0.093	0.187
0.875	22.2	0.6013	1700	1.00	60-65	0.125	0.250	1700	1.00	65	0.125	0.250	Not Recommended				
1.000	25.4	0.7854	1900	1.40	85	0.125	0.250	2050	1.40	85	0.125	0.250	Not Recommended				

Note 1: These welding parameters should be considered as an initial setup guide for the stud diameter and position being welded. They should produce satisfactory results, but should **not** be considered so restrictive that they prevent modification based on physical and visual test evaluations of the finished welds as outlined in AWS D1.1 Structural Welding Code — Steel, AWS D1.6 Structural Welding Code — Stainless Steel and/or AWS C5.4 Recommended Practices for Stud Welding, which would assist in finalizing the weld setup based on the conditions and equipment at the production welding site.

Note 2: 1 in. = 25.4 mm; 1 sq in. = 645 mm².

verification measurement of both weld time and current.

Current controls can adjust for weld cable resistance, compensate for incoming power fluctuations, and provide system shutdown in the event of variations from the set weld parameters. As another example, welding guns with potentially erratic pneumatic weld plunge dampeners have been upgraded to very reliable, self-contained, sealed hydraulic dampener controls.

STUD WELDING SETUP

An understanding of the settings and adjustments and their relationship with weld quality is needed to ensure consistent stud welding results. The following definitions of specialized stud welding terms will make the narrative easier to understand.

- **Plunge** is the length of stud that protrudes beyond the ferrule. This portion of the stud is available to be “burned off,” or melted, to develop the weld fillet. A short plunge may cause

excessive splatter and high or uneven fillet formation. Plunge is a physical measurement set and measured with the stud and ceramic ferrule in place on the stud gun (see Fig. 2).

- **Lift** is the distance the gun pulls the stud away from the base material. Before the weld is started, the stud and base metal are in contact. Lift creates an air gap that the electric current must bridge. The current flow across the resistance of this gap creates the arc heat to melt the stud and base material.

If no gap exists, the current will not create sufficient heat to fuse the metal. A short lift may allow the molten metal to bridge the arc gap, resulting in a cold weld. An excessively long lift increases the chance of having arc blow and welds that are bonded on only one side of the fillet. Lift is physically set on the stud gun and is measured when the stud weld is initiated. Lift should be set and measured by placing the stud and ferrule on a nonconductive surface and initiating the weld cycle so that an actual molten weld is not made.

- **Time** is the duration of the weld. On thin base material, a shorter time and higher amperage can be used to achieve sufficient heat and prevent melting through the base material. On some base materials, a longer time and lower amperage improve the ductility of the weld zone. Weld time is set on the time setting indicator of the control system.

- **Amperage** is a measure of the current from the power source that flows across the air gap created by the lift.

Fig. 6. Typical tension test fixture (Reference 8).

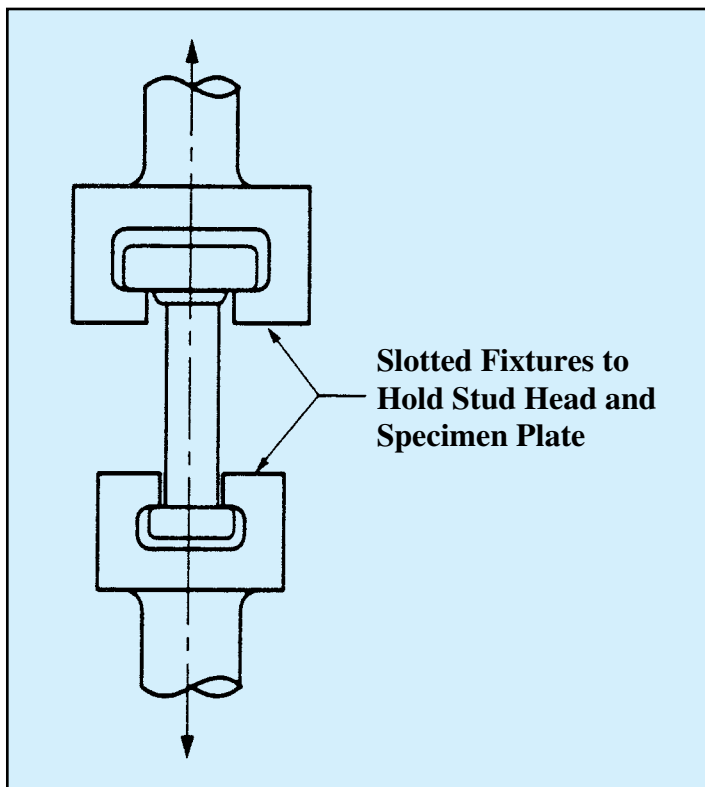

Increasing the amperage increases the weld heat. As with the time setting, a higher amperage setting is needed for larger stud sizes. Amperage is also set on the control system's current setting indicator.

- **Alignment** is the proper centering the stud in the ceramic ferrule so that the stud does not contact the ceramic ferrule during lift and plunge, which can cause friction or binding between the stud and ferrule. Binding can inhibit both stud lift and stud plunge sufficiently so that there is less than sufficient stud melting and less than full penetration into the molten weld pool, resulting in a less than full strength weld.

Table 3 contains suggested weld settings.¹⁴ These settings are suggested starting points for obtaining a final setup. The final setup is verified by visual inspection, after weld measurements and physical testing to confirm weld quality. Other factors such as welding system grounding, base plate composition, and cable connections can influence the weld settings.

Stud welding manufacturers are required by AWS codes^{8,11} to qualify their standard stud weld base diameters by 60 stud tests of each stud diameter with the current at plus or minus 10 percent from optimum [except in the case of $\frac{7}{8}$ and 1 in. (22 and 25 mm) diameters, which are plus or minus 5 percent]. The tests require bending and tensile testing all of the studs to failure without failure in any weld. Current range variations in the test provide an indication of the acceptability of the welds under conditions that can occur in actual shop or field welding production.

Figs. 6, 7, and 8 illustrate typical fixtures used for stud base tests, which include the alternating 30-degree bend test at a distance of 2 in. (51 mm) from the stud weld.^{8,11} Fig. 9 shows acceptable and unacceptable weld failures.⁸

STUD WELDING PRACTICE

Proper implementation of the practices presented in this section will result in successful stud welding products. As in other welding and fabricating methods, there are some general guidelines to consider when

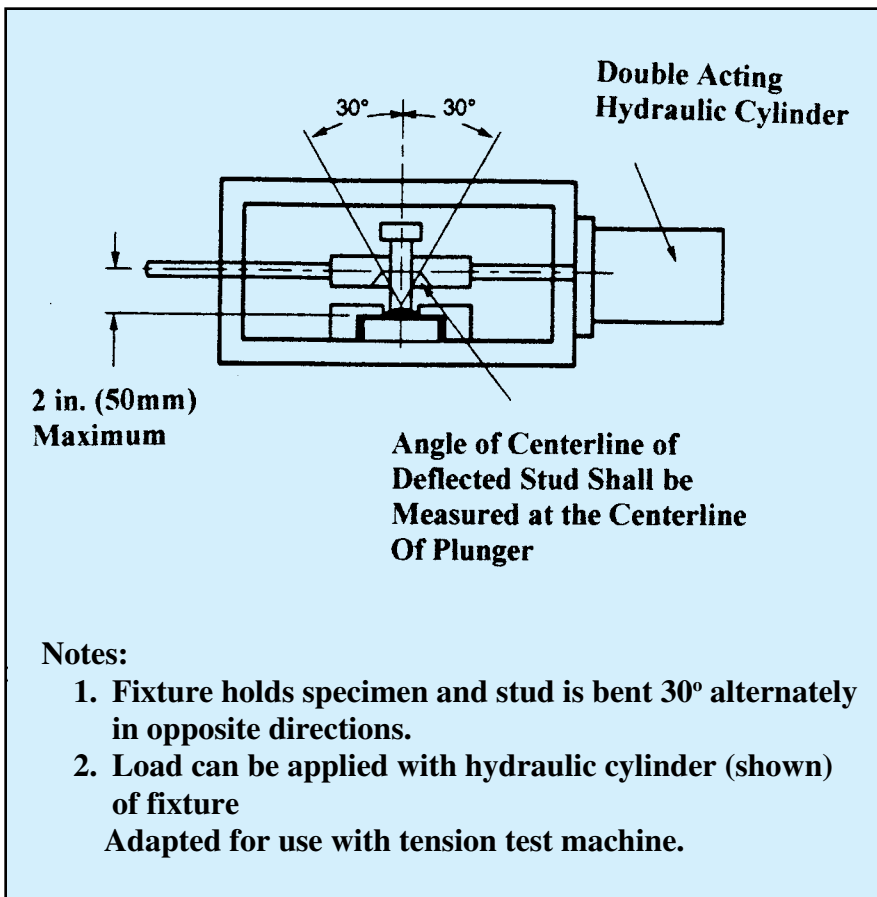

Fig. 7. Bend testing device (Reference 8).

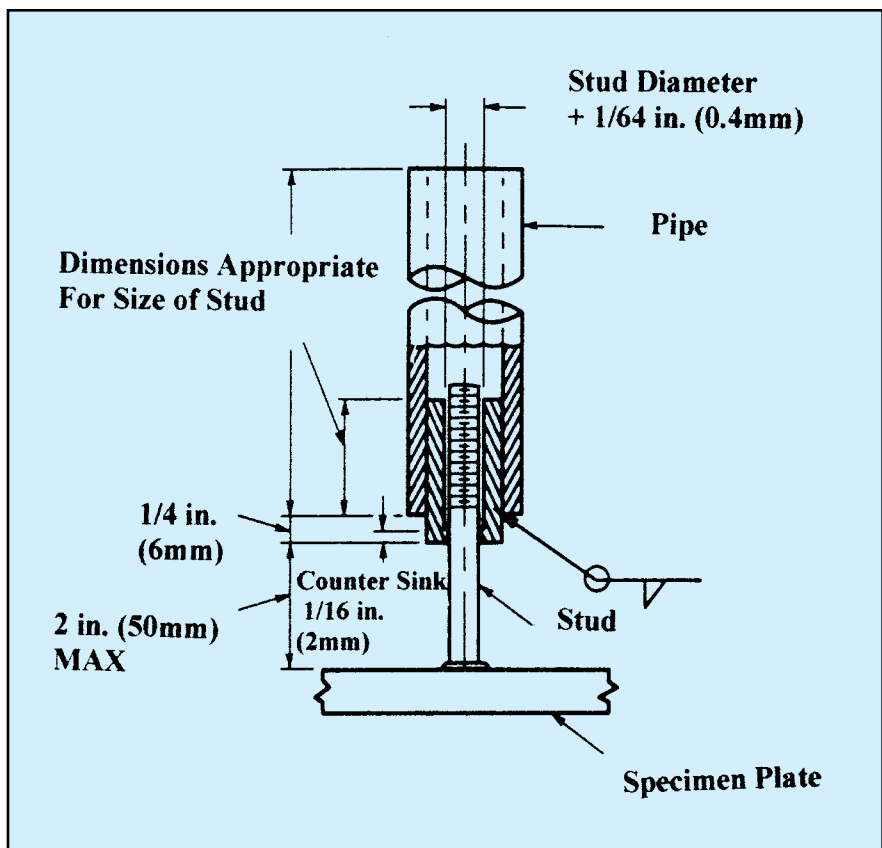

Fig. 8. Suggested type of device for qualification testing of small studs (Reference 8).

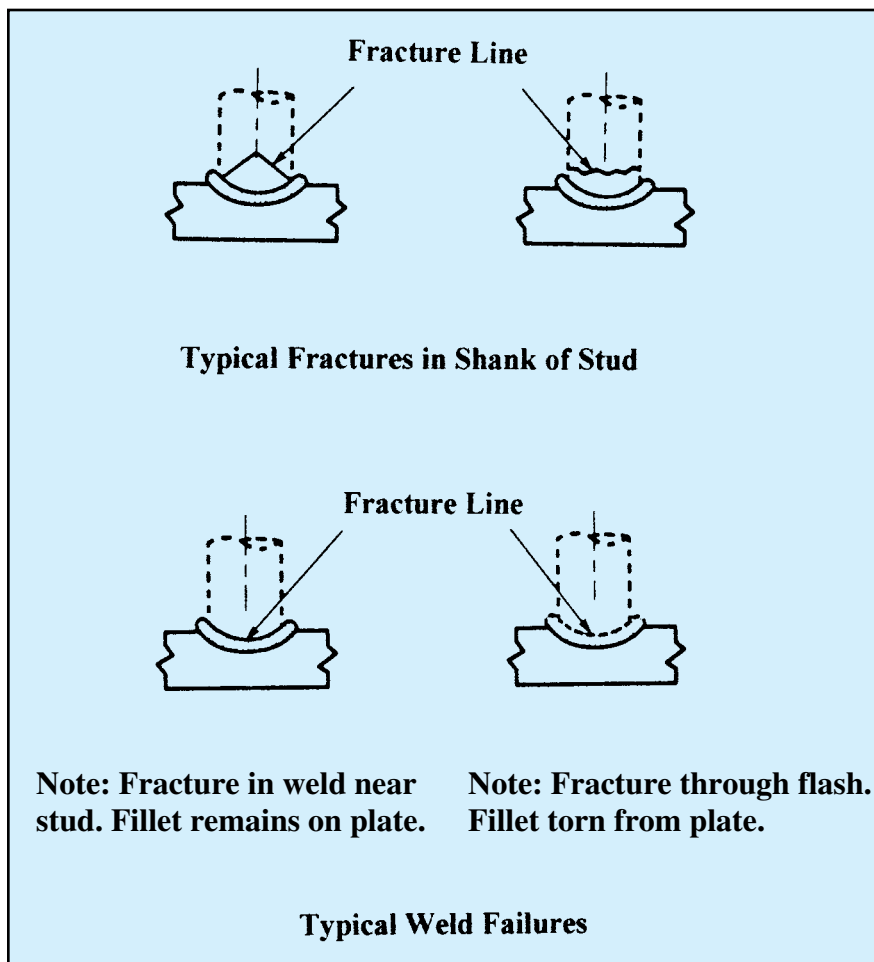

Fig. 9. Typical acceptable stud failures and typical unacceptable weld failures.

determining the basics of good practice. Among these are the following considerations:

Weld Plate Thickness— A plate thickness that is at least 0.33 times the stud shank diameter will develop the full steel tensile and shear capacity of the stud. It is possible, however, that this ratio of stud diameter to plate thickness will cause unacceptable distortion and bending when high loads are applied. A minimum plate thickness of one-half the stud diameter is often specified and is recommended in the PCI Design Handbook.¹⁵ Plate bending should always be a consideration in any embedment plate design.

Weld Plate Cleanliness— The area where the stud is to be welded (weld spot) should be as clean as possible. The spot where the ground clamp is fastened should also be cleaned on both sides of the plate so that a good current path is established.

The presence of light rust or light mill scale is not usually detrimental.

Heavy mill scale or heavy, flaky rust should be removed, as well as any deleterious coating such as heavy oil, paint, galvanizing, grease, and moisture. Weld and ground spots can be cleaned very quickly with an abrasive wheel, wire brush or wheel, drill burr, or end mill.

Note that solid grinding wheels or abrasive discs do not remove zinc galvanized plating very well. The grinding disc or wheel fills with zinc and does no more than spread the zinc plating around, making the weld spot look shiny and clean. Open pore abrasive discs and grinding burrs are better options for removing galvanizing. When zinc galvanizing is used to coat studs, the coating should be removed from the weld end by the stud manufacturer before the studs are shipped and welded.

Galvanizing— Even though zinc galvanizing is electrically conductive, studs should not be welded to a galvanized plate. Zinc is a contaminant that

affects the weld metallurgy, causing brittle welds. Galvanizing should be done after, rather than before, the base plate has been welded to the stud.

The effects of hydrogen embrittlement should be considered when hot dip galvanizing is used. Hydrogen embrittlement can have several points of origin, which can cause serious brittleness in the weld stud shank when studs are bent to a very tight bend diameter. Causes of hydrogen embrittlement are improper pickling of the finished weld plate, either by pickling too long or not rinsing thoroughly after pickling; plating too long or at too high a temperature; and using a stud that is of a much higher strength than the base plate material strength.

To prevent embrittlement in the bend area of bent bar studs, the bending radius in studs to be zinc plated should be four to six times the stud diameter as provided by the ACI Building Code.¹⁶

Edge Distance— Studs should be placed no closer to a base plate free edge than the stud diameter plus $\frac{1}{8}$ in. (3 mm) to the edge of the stud base. This distance should be at least 1 to $1\frac{1}{2}$ in. (25 to 38 mm) from each free edge.

Grounding/Arc Blow— Edge distance and ground placement can influence weld quality due to arc blow; that is, the welding arc is electromagnetically deflected toward the grounding point or toward the larger mass of the base plate configuration being welded. Fig. 10 shows typical ground and edge effect patterns due to arc blow.¹⁷

These effects are less noticeable when large masses of steel are present, such as in large beams, but relatively small embedment plates can present difficulties. Typically, there is a lack of weld fillet on the periphery of the stud opposite the direction of the arc blow that can adversely affect weld strength and quality.

As an example, a welding platen table may be grounded at all four corners by four separate ground wires bolted to the table and joined to the welding system single ground wire by a bolted connection. This turns the entire platen into a grounded mass and arc blow on a small plate set onto the table is minimized. On longer, rect-

angular plates, a double ground (one at each end on opposite edges of the plate) provides a good current flow pattern.

Ground connections may be screw type “C” clamps, fast action spring clamps, or lever action hold-down clamps mounted to the welding table and connected to the stud welding system ground cables. All of these types have proven successful. Frequently, a copper or steel plate larger than the base plate to be welded, with a center ground bolted to the bottom, will eliminate or minimize the effects of arc blow.

Weld splatter, weld berries, and ferrule pieces should be removed from the weld plates so that the surface contacts the weld plate cleanly and evenly. This will ensure good electrical contact and current flow. It may take some time and a few trials to establish a good current flow path for the typical base plate configuration. When proper grounding is established and arc blow is minimized, the result is a consistent high quality weld with a low rate of rejection and decreased repair costs.

Ceramic Ferrules— These pieces are also called ceramic arc shields. Ferrules serve several functions. First, they contain the pool of molten metal and form it into the fillet (flash) formed around the periphery of the stud. Second, they control to a great extent the amount of arc brightness and the quantity of sparks expelled during the weld. Third, they are designed with specific vent patterns so that when the arc is initiated, the flux in the stud end is consumed and deoxidizes the weld zone by expelling weld gasses through the vents, thus preventing oxygen from entering the weld area.

Ferrules are also available in a wide variety of configurations to allow studs to be welded to round tubing and bars, plate edges, channels, struts, rectangular and square structural tubing edges. These various configurations also allow for a number of weld positions other than downhand.

It is important to keep the ferrules dry. If they absorb too much moisture, the weld instantly turns the moisture into steam with a substantial amount of molten metal expelled. In addition

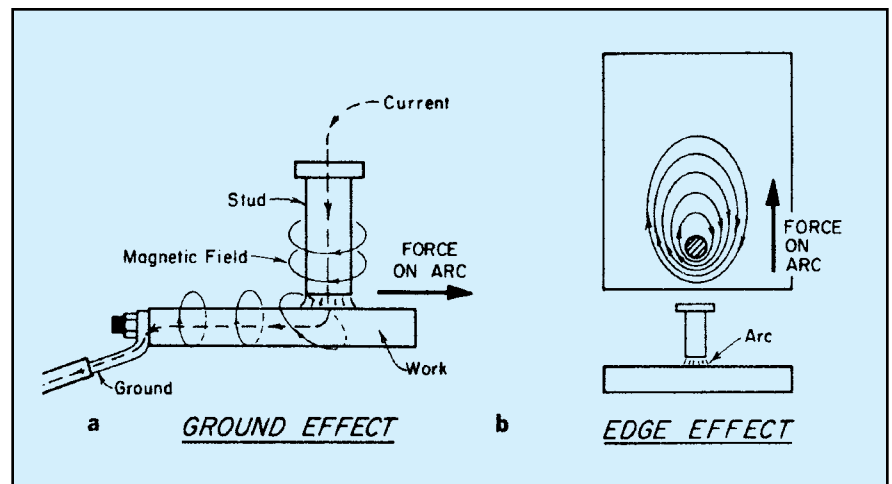

Fig. 10. Effect of (a) Ground connection, and (b) Workpiece on distortion of magnetic field (Reference 17).

tion to the possible danger from this “explosion,” the weld is made very porous and weak. Ferrules that have been wet or have absorbed moisture can be dried by heating them to 250°F (121°C) until the moisture is gone.

Ferrule cartons are marked with a warning that they contain silica, a possible health hazard. Because the ferrules are made from “green” fireclay with binders and fired at high temperatures, there is no free silica material in respirable sizes released during the weld. If simply broken free of the weld, they are basically an inert, inorganic material, such as fired aggregate or rock, and may be disposed of easily and safely. It would take an enormous amount of ferrule breakage or grinding to produce a dangerous health hazard to the stud welding operator or those nearby.

Position Welding— Studs of all weld base configurations and diameters can be easily welded in the downhand position. As a general rule, studs up to $\frac{3}{4}$ in. (19 mm) in diameter can be welded to the weld plate in a vertical position with consistent full strength results. Special ceramic ferrules are used with studs $\frac{5}{8}$ in. (16 mm) and larger when welding to the vertical position of the plate. There is a special ceramic ferrule for welding $\frac{7}{8}$ in. (22 mm) diameter studs to the vertical position of the plate, but welding this diameter with the base plate vertical requires very carefully controlled conditions.

Welding overhead can also be done

with all stud diameters. Naturally, the overhead position causes an increased amount of welding sparks to fall during welding and suitable operator protection is needed. There are spark retention accessories available from the stud manufacturer. Welding positions are shown in Fig. 11.¹¹

Stainless Steel Studs Welded to Carbon Steel Base Plates— Full strength welds are made when standard carbon steel studs are welded to either approved stainless steel or carbon steel base plate materials. Similarly, welds made with stainless steel studs to stainless or carbon steel base plate materials develop full stud steel capacity in tension or shear. However, in cases where stainless steel studs are welded to carbon steel plates and are to be subject to repetitive or cyclic loads, stress corrosion failure in the weld can occur, initiated by carbide precipitation during the weld and subsequent intergranular cracking.

As an example, on one project, stainless threaded studs were welded to low carbon structural steel to secure counterweight vibration dampers exposed to open weather conditions. The constant movement of the dampener weights and repetitive loading cycles on the studs produced cracking, corrosion and failure in the stud welds.

It is good practice to specify that the stainless studs to be used under such conditions are either annealed after manufacture or made from annealed in-process stainless steel with less than 90 Rockwell B Hardness in the

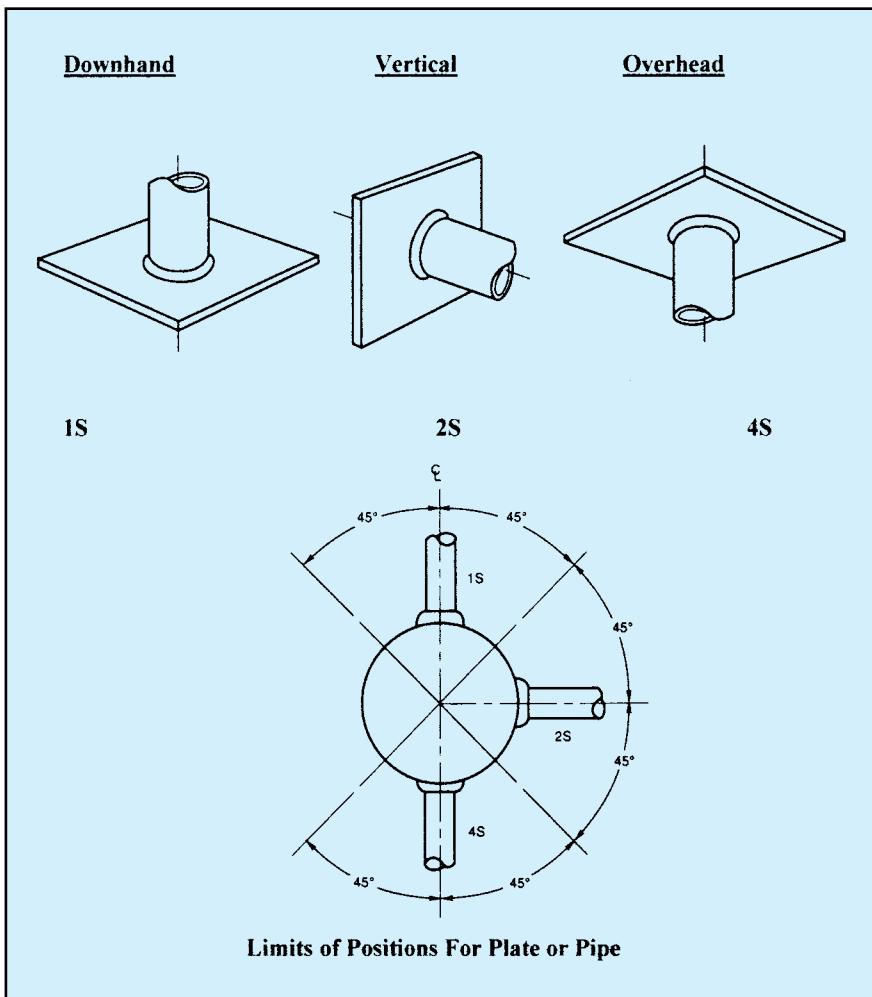

Fig. 11. Positions for stud welding (Reference 11).

finished condition. This minimizes the chance of weld cracking and failures.

Material Selection and Verification

Studs are made from steel supplied to the stud manufacturer by quality approved steel suppliers. Quality assurance procedures require that the steel supplier provide certified mill test reports (CMTRs) for each heat and diameter of steel supplied. These CMTRs certify compliance to welding code specified material grades and chemistry. These reports are requested at the time of purchase from the stud manufacturer and are part of their certification package on every shipment of studs.

At the time of manufacture, stud heats are also tested to determine whether their mechanical properties are in compliance with welding code requirements. A certificate of compliance (COC) for each stud shipment

can be made at the time of shipment to verify that chemical and physical properties comply with the specifications of the engineer.

A COC can certify compliance with typical steel specifications such as ASTM A 108⁹ and A 276,¹³ as well as various welding codes such as AWS D1.1,⁸ AWS D1.6,¹¹ CSA W59,¹⁸ and ISO 13918.¹⁹ Similarly, the weld plate fabricator should require certified mill test reports from their steel vendors to verify compliance to welding code-approved materials.

As mentioned previously, welding codes require stud manufacturers to weld test and qualify their stud base diameters and materials. These tests must be certified by an independent testing laboratory, which will either conduct or witness the testing. Along with the stud COCs and CMTRs for both studs and weld plates, the stud weld base qualifications should be kept on file with the weld plate fabri-

cator to verify compliance with quality programs and welding codes.

Stud Welding at Low Temperature— Studs should not be welded when the base plate temperature is below 0°F (-18°C) or when the surface of the base plate is wet, covered with frost, or exposed to rain or snow. When the base plate is below 50°F (10°C), impact testing of the welded stud, such as with a hammer blow, should not be done. Instead, the stud should be tested by bending it slowly with a hollow pipe or other bending device. A brittle failure by impact testing at low temperatures in the weld or in the base metal is quite common.

Tension and shear tests done at temperatures as low as -40°F (-40°C) on studs welded at -40°F have shown no loss in weld strength.²⁰ It is the impact testing that causes the weld failure. Whenever possible, welding and testing studs at low temperatures should be avoided; if indeed it is necessary, the bend test should be done with a pipe instead of a hammer.

Training and Qualification of the Stud Welding Operator

The following section discusses training of operators and process qualification.

Operator Training— Introductory training of operators in the stud welding process is the first step in successful production stud welding. This familiarizes the operators with the general principles of the process, proper equipment setup, weld setup for the studs, general guidelines, and inspection techniques. Trained and experienced representatives of stud and equipment manufacturers can provide specifications, guidelines, and other literature as part of a complete program that will lead to formal qualification of both the operator and the stud welding process.

Process Qualification— Stud welding is a prequalified process unique among the many welding processes due to the many millions of studs that have been successfully welded using the process. When studs are welded in the downhand position to approved base plate materials, only two studs are required to be welded and tested.

The test consists of both a visual and physical inspection.

The physical inspection requires bending the studs 30 degrees from the vertical by hammering the stud on the unwelded end or bending it with a pipe or other device. The pipe should be placed 2 in. (51 mm) above the stud weld. The visual inspection verifies that the stud flash is complete around the stud periphery, and that the after-weld height of the stud is appropriate for the diameter being welded.

If the physical and visual inspection are each satisfactory, then both the process and the operator are considered qualified for those stud diameters welded downhand. This qualification applies as long as there are no changes made in the studs, settings, equipment, welding cables, or ceramic ferrules, or from an approved to a non-approved base material qualified by the test. The two-stud test is required at the start of every production period, such as a shift change or operator change.

Studs welded to a non-approved base plate material or in a position other than downhand, such as to a vertical or overhead base plate, or the fillet or heel of an angle, must be application qualification approved. Qualification approval consists of welding ten of each stud style and diameter to be used in production to the positions and base materials to be used in production, with the same equipment, settings, welding cables and ceramic ferrules to be used in the actual production welding.

All ten studs of each diameter and in each position to be qualified must be tested to failure by tensile, bend, or torque test, or a combination of these. They must also meet visual inspection requirements. For all studs tested, failure must be in the stud shank or base plate material, rather than in the stud weld. Note that failure is allowed in the base plate material.

This provision is acceptable only when it is known the base plate material may be of a composition, strength or thickness that will not fully develop the stud weld strength, but the strength and weld results are acceptable for the end use intended. Such a failure is not acceptable for embedment plates used for structural connections nor for at-

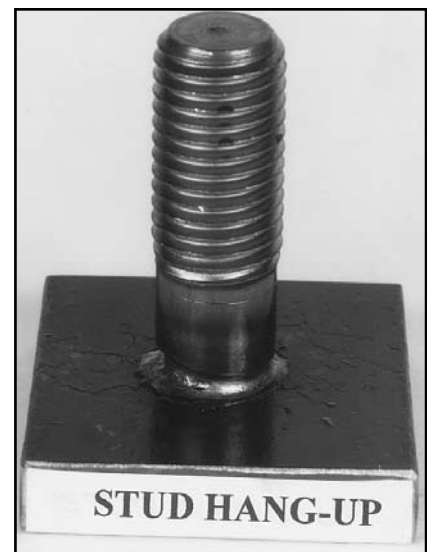

Fig. 12. Visual inspection of stud weld appearance. Source: Nelson Stud Welding, Inc.

tachments requiring full strength and ductility. The successful completion of the specific application qualification tests qualifies both the operator and the process.

Qualification documentation for the operator and the process should be part of the overall recordkeeping of the plate fabrication facility. This documentation can be completed by first establishing a Welding Procedure Specification (WPS) and Procedure Qualification Record (PQR) for the stud diameters, equipment, settings, cable lengths, welding positions, weld plate materials, and ceramic ferrules that are to be used in the weld plate fabrication.

Once the welding procedure specifications are completed and documented, the operators set up and per-

form the welding procedure using the WPS guidelines. The operator welds two studs of all diameters downhand and ten studs for all other positions. The welds are visually inspected and tested with the testing certified by the welding supervisor or trainer. The operator is certified by name using the same form as a Welder Qualification Record (WQR).

These records are retained along with material certifications and production inspection records as part of the documentation files for review by interested parties including customers, quality certification agencies, the engineer of record, and the owner's representative. A sample WPS/PQR/WQR form for stud welding is provided in AWS D1.1.⁸

Inspection Guidelines

Visual Weld Inspection— A proper relationship between the lift, plunge, time, and amperage is needed to obtain good weld results. The length reduction or burn-off and the weld fillet appearance are determined by the weld settings. Referring to Fig. 12, visual weld inspection consists of interpreting the appearance of the weld fillet, and is normally a very accurate method if certain guidelines are followed.

A “good weld” is characterized by:

- Even flash (fillet) formation
- A shiny, bluish hue to the flash surface
- A slight flow or bend of the flash metal into the base material
- Good flash height
- Consistent after-weld length
- Full “wetting” – i.e., flash around the stud periphery without undercut

A “cold weld,” which requires more time, amperage, or both, is indicated by:

- Low flash (fillet) height
- Incomplete flash formation
- A dull gray cast to the flash surface
- Stringers of flash metal forming “spider legs”

A “hot weld,” which is made with too much time, amperage, or both, is distinguished by:

- Excessive splatter
- A washed-out flash (fillet)
- Undercutting of the stud
- Burn through the base material

“Stud hang-up” can result from too much lift, poor alignment of the stud relative to the work piece, and binding during lift and plunge caused by poorly centering the stud in the ceramic ferrule. Stud hang-up is distinguished by:

- Very low or no flash (fillet)
- Severe undercut in the weld
- No penetration of the weld into the base plate
- Insufficient stud burn-off (after weld height is too long)

Burn-Off – Stud Length Reduction— In most arc welding processes, the weld fillet metal comes from a stick electrode or a spool of welding

wire. In stud welding, a portion of the stud itself is the source of the fillet metal. The stud material that is melted to develop the fillet is called burn-off. The difference in length between a welded stud and the original length is the burn-off length.

The burn-off length is a very good measure of weld quality, because the burn-off is determined by the weld settings of time, current, lift, and plunge. Proper burn-off also indicates that there was no binding or hang-up during the plunging motion of the gun.

The most convenient method of checking burn-off is to stand an unwelded stud upside down (load end up) next to a welded stud to compare the length difference to the stud base – not to the end of the flux load. After-weld height can also be checked with a sliding carpenter’s level or square. Table 4 shows typical burn-off length reductions when welding to the bare plate.²¹

Physical Weld Inspection— At the beginning of the day, shift change, or any change of operator, equipment, position, or settings, two studs are welded according to qualified settings during pre-production testing. Following satisfactory visual inspection, they are bent 30 degrees (or torque tested in the case of threaded studs). Studs that are bent may be straightened to the original axis and used in production. However, studs should not be heated during bending nor straightening without approval by the engineer of record.

Torque testing is performed to a proof load level slightly lower than the nominal stud yield to prevent permanent distortion of the threads. Torque test proof load requirements are found in AWS D1.1 or D1.6. The torque test studs may be used in production.

The stud welding operator is responsible for pre-production setup and testing. The operator shall weld two studs to a production weld plate, or to a piece of material similar to the weld plate in material composition and within 25 percent of the production weld plate thickness.

Inspections during production are also the responsibility of the operator. Pre-production and production inspection test results should be recorded and approved by the welding supervisor.

Table 4. Stud burn-off lengths.²¹

Stud diameter	Length reduction
$\frac{3}{16} - \frac{1}{2}$ in.	$\frac{3}{32} - \frac{1}{8}$ in. (2.4-3 mm)
$\frac{5}{8} - \frac{7}{8}$ in.	$\frac{5}{32} - \frac{3}{16}$ in. (4-5 mm)
1 in. and over	$\frac{3}{16} - \frac{1}{4}$ in. (3-6 mm)

Note: 1 in. = 25.4 mm.

Unsatisfactory pre-production or production inspections and tests should be brought to the welding supervisor’s attention and corrections made. This should be accompanied by additional tests with fully satisfactory inspection and test results before proceeding with further welding.

At regular intervals during production welding, the studs welded since the previous testing interval should be inspected visually. If the visual inspection shows a full periphery weld flash without undercut and satisfactory after-weld length, welding may continue. If the visual inspection shows a lack of fillet or insufficient weld burn-off, the questionable studs should be marked and appropriate supervisory personnel notified.

In accordance with codes, the contract documents, or the quality assurance inspection criteria in use, the studs without a full peripheral fillet but with a satisfactory after-weld length may be tested by bending 15 degrees in the direction opposite the lack of fillet, or repaired with a hand weld by adding a minimum fillet weld as required in Table 5.⁸ The repair weld shall extend at least $\frac{3}{8}$ in. (10 mm) beyond each end of the discontinuities being repaired.

If any tested stud fails the bend test or if there is continued and frequent evidence of insufficient stud burn-off, or incomplete fillet, production must be halted and appropriate supervisory personnel notified. The welding variables should be checked, the necessary adjustments made and the process and operator qualification procedures repeated with satisfactory results before continuing with further production welding.

In many cases, the fabrication of stud welded embedment plates may be subcontracted to an outside supplier. The weld plate fabricator’s inspection procedure and inspection results should be made available to the pre-

Table 5. Minimum fillet weld sizes for studs.^{8*}

Stud diameter		Minimum size fillet	
in.	mm	in.	mm
1/4 through 7/16	6.4 through 11.1	3/16	5
1/2	12.7	1/4	6
5/8, 3/4, 7/8	15.9, 19.0, 22.2	5/16	8
1	25.4	3/8	10

Note: 1 in. = 25.4 mm.

* Welding shall be done with low hydrogen electrodes 5/32 or 3/16 in. in diameter except that a smaller diameter electrode may be used on studs 7/16 in. diameter or under or for out-of-position welds.

cast/prestressed producer. Further, the producer should implement an incoming inspection procedure with acceptance, rejection and corrective action criteria and corresponding records.

An excellent welding inspection procedure can be found in PCI's Manual for Quality Control for Plants and Production of Architectural Precast Concrete Products.²²

Equipment Service and Repair

The following section discusses safety precautions to be taken in the event of malfunctioning equipment and stud welding operations.

Malfunctioning/Obsolete Equipment and Maintenance— Older stud welding units with mechanical contactors and relays powered by a separate motor generator or transformer rectifier are obsolete. These systems lack read-out displays for time and current, current compensation, fault protection, and shut down, which allow controlled quality welds. Spare parts for these systems are not readily available.

Newer equipment is solid state, but even a new system can suffer breakdowns. Welding cable connections can deteriorate, wiring connections can become brittle and fail, and the accumulation of heavy dust or moisture can cause the solid-state components to overheat and short out. Parts in the welding gun can suffer wear or breakage, affecting the consistency of programmed weld setup parameters.

It is good practice to regularly clean the welding systems and to inspect and replace worn or defective parts. Trained representatives of the equipment and stud supplier are usually available to assist in evaluating the equipment and cleaning guns or suggesting which components may need to be replaced.

Stud Welding Safety— As with any welding process, common sense should be applied for the safety of the stud welding operator and welding station facilities. The welding area should be kept clear of any flammable materials, gases, and falling and tripping hazards. The operator should also wear welding safety glasses with No. 3 tinted lenses, protective gloves, welding aprons, and other protective clothing as needed for the setup of the welding table and welding position. For example, a welding table at waist height may subject the operator to sparks from the weld process, in which case a welding apron should be used.

Welding cables should be regularly inspected for such things as loss of insulation and exposed connections. Any necessary repairs should be made without delay. Finished weld plates must be handled carefully as they can become very hot during or shortly after welding is completed. The work area should be adequately ventilated so that welding fumes are exhausted from the area.

Welding arc brightness is minimized due to the ceramic ferrule, but continual observation of the weld should be avoided and tinted lenses are recommended. The sparks that are caused by stud welding are usually minimal and do not carry for a long distance, but workers should be at least 5 ft (1.52 m) away from each other. These safety practices and other precautions are outlined in ANSI/ AWS Z49.1.²³

CONCLUSIONS AND RECOMMENDATIONS

Stud welding is a long recognized and practiced welding method. In any given year and throughout the world, over 100 million stud welds of all types are made with the requirement

for development of full weld strength. Quality welds are critical to the performance of finished structural members, attachments, and connections. Whether the user employs the welding procedure in their in-plant fabrication shop or purchases the finished weld plates from a subcontractor, the principles and practices discussed in this article should be followed. The following summary recommendations are given for achieving consistent quality.

Stud and Weld Plate Materials

1. Studs should be manufactured from materials acceptable for the stud welding process as approved in the AWS welding codes. The stud manufacturer should be required, by specifications from the purchaser, to provide certified material test reports on the material used to make the studs. The manufacturer should also be required to provide certificates of compliance verifying that the shipped studs meet the AWS codes and engineering specification requirements provided by the purchaser in the purchase documents.

2. Base plate materials should also meet the requirements for AWS code approved materials for use with stud welding and appropriate certifications should be required for the base materials from the steel manufacturer or the plate supplier. In both cases, the steel certification documents are part of the fabricator's quality control system and should be maintained in their records and be included in the purchaser's or user's documentation package.

Welding and Inspection

1. Stud welding training, equipment setup, welder qualification, and unique application qualification instruction are available from stud and equipment suppliers, and fabricators should avail themselves of these services. The records for such training can be incorporated into an appropriate quality assurance program.

2. Inspection of pre-production welds and continuous and documented results of both visual and physical inspection of finished welds is further assurance of acceptable weld quality.

Stud Welding Equipment

and Safety

1. Equipment for stud welding has grown much more reliable than in past years, and improvements in the technology are ongoing. Obsolete equipment may not function properly and should be considered for replacement. All pieces of operating equipment are subject to wear or possible failure.

Equipment must be regularly inspected, repaired, or replaced as needed.

2. Welding safety for both operators and other personnel in the welding area is a matter of common sense. Publications are available with guidelines for safety. Safety increases productivity.

ACKNOWLEDGMENT

The author wishes to express his appreciation to the PCI JOURNAL reviewers for their thoughtful and constructive comments.

REFERENCES

1. *Stud Welding Applications: Concrete Connections*, Nelson Stud Welding, Inc., Elyria, OH, 1988.
2. Anderson, Neal S., and Meinheit, Donald F., "Design Criteria for Headed Stud Groups in Shear: Part 1 – Shear Capacity and Back Edge Effects," *PCI JOURNAL*, V. 45, No. 5, September-October 2000, pp. 36-75.
3. Strigel, Roberta M., Pincheira, José A., and Oliva, Michael G., "Reliability of $\frac{3}{8}$ in. Stud-Welded Deformed Bar Anchors Subject to Tensile Loads," *PCI JOURNAL*, V. 45, No. 6, November-December 2000, pp. 72-82.
4. Wiewel, Harry, "Load Capacity of Nelson D2L Deformed Bar Anchors Installed in Concrete," Nelson Stud Welding, Inc., Elyria, OH, September 1986.
5. Wiewel, Harry, "Report of Tests Conducted on Nelson D2L Deformed Bar Anchors Installed in Stone Aggregate Concrete," Nelson Stud Welding, Inc., Elyria, OH, December 1994.
6. ACI Committee 355, "State-of-the-Art Report on Anchorage to Concrete," ACI 355.1R-91, American Concrete Institute, Farmington Hills, MI, 1991.
7. *Welding Handbook*, Eighth Edition, V. 2, Welding Processes, Chapter 9, Stud Welding, American Welding Society, Miami, FL, 1991, pp. 300-327.
8. ANSI/AWS D1.1-00, *Structural Welding Code—Steel*, American Welding Society, Miami, FL, 2000.
9. ASTM A 108-99, "Standard Specification for Steel Bars, Carbon, Cold Finished, Standard Quality," American Society for Testing and Materials, West Conshohocken, PA, 1999.
10. ASTM A 496-97a, "Standard Specification for Steel Wire, Deformed, for Concrete Reinforcement," American Society for Testing and Materials, West Conshohocken, PA, 1999.
11. ANSI/AWS D1.6-99, *Structural Welding Code—Stainless Steel*, American Welding Society, Miami, FL, 1999.
12. ASTM A 493-82a, "Standard Specification for Stainless and Heat Resisting Steel for Cold Heading and Cold Forging," American Society for Testing and Materials, West Conshohocken, PA, 1999.
13. ASTM A 276-00, "Standard Specification for Stainless Steel Bars and Shapes," American Society for Testing and Materials, West Conshohocken, PA, 2000.
14. Training Program, Nelson Stud Welding, Inc., Elyria, OH, 2000.
15. *PCI Design Handbook: Precast and Prestressed Concrete*, Fifth Edition, MNL 120-99, Precast/Prestressed Concrete Institute, Chicago, IL, 1999.
16. ACI Committee 318, "Building Code Requirements for Structural Concrete (ACI 318-99) and Commentary (ACI 318R-99)," American Concrete Institute, Farmington Hills, MI, 1999.
17. Baeslack, III, W. A., Fayer, III, G., and Jackson, C. E., "Quality Control in Arc Stud Welding," *The Welding Journal*, November 1975, pp. 789-797.
18. CSA W59-89, "Welded Steel Construction (Metal Arc Welding)," Canadian Standards Association, Rexdale, Ontario, Canada, 1989.
19. ISO 13918:1998, "Welding—Studs and Ceramic Ferrules for Arc Stud Welding," International Organization for Standardization, Geneva, Switzerland, 1998, 21 pp.
20. Kennedy, D. J. Laurie, "Stud Welding at Low Temperatures," *Canadian Journal of Civil Engineering*, V. 7, 1980, pp. 442-454.
21. ANSI/AWS C5.4-94, "Recommended Practices for Stud Welding," American Welding Society, Miami, FL, 1994.
22. *Manual for Quality Control for Plants and Production of Architectural Precast Concrete Products*, Third Edition, MNL 117-96, Precast/Prestressed Concrete Institute, Chicago, IL, 1996.
23. ANSI/AWS Z49.1-94, "Safety in Welding, Cutting and Allied Processes," American Welding Society, Miami, FL, 1994.