

DESIGN, FABRICATION, AND ASSEMBLY OF A TESSELLATED PRECAST CONCRETE WALL

Grace F. Crocker, EIT, Clemson University, Clemson, SC
Brandon E. Ross, PhD, PE, Clemson University, Clemson, SC
Michael Carlos Kleiss, PhD, Clemson University, Clemson, SC
Pinar Okumus, PhD, University at Buffalo, Buffalo, NY
Negar Elhami Khorasani, PhD, University at Buffalo, Buffalo, NY
John Michael Romano, EIT, Tindall Corporation, Spartanburg, SC

ABSTRACT

This paper describes the fabrication and assembly of tessellated precast reinforced concrete shear walls. These walls are being constructed and tested as part of an NSF-funded research project designed to demonstrate the concept of Tessellated Structural-Architectural (TeSA) systems. The over-arching goal of this research is to explore tessellation patterns that can be implemented on a large scale, are architecturally appealing, and provide structural function. TeSA systems are comprised of individual tiles arranged in tessellations, or repeating geometric patterns. Tiles are topologically interlocking, which means that they transfer forces due to their interlocking geometry rather than through a bonding adhesive. The benefit of such a system is the ability to localize failure and rapidly repair the individual damaged tiles, rather than the entire system. The specimen discussed in this paper is a precast concrete shear wall constructed from individually cast I-shaped tiles. Shear wall tests are forthcoming; this paper focuses instead on documenting technical solutions to difficulties faced during design, fabrication, and assembly of the test specimen. This paper is intended to provide lessons learned to others who are designing and building TeSA walls and thereby facilitate the benefits of these novel systems.

Keywords: Tessellation, Precast, Constructability, Experimental Setup, Topologically interlocking

INTRODUCTION

Tessellated Structural-Architectural (TeSA) systems utilize repeating geometric patterns known as tessellations in structural applications. One such application is that of a structural shear wall comprised of topologically interlocking precast reinforced concrete tiles. Such a wall combines the architectural appeal of tessellations with the load resistance capability of a structural shear wall. One potential benefit of a TeSA shear wall is that of localized failure; due to the discrete tiles, cracks in a given tile may not propagate throughout the wall as they typically would in a monolithic shear wall. Instead, the damage may be isolated to a few tiles, allowing for rapid repair in the form of replacement of the damaged tiles. Additionally, because TeSA systems are built of repetitive discrete tiles, they are suitable for prefabrication, automated construction, reconfiguration, disassembly, and reuse. Thus, TeSA systems can contribute to resilience through rapid repair and to sustainability through reuse (Ross et al. 2020).

Tessellations are defined mathematically as patterns of repeating convex shapes with no gaps or overlap (Magnus 1974). An example of such a pattern can be found in Figure 1 (left). However, in an architectural context, it is acceptable to loosen this definition to a certain degree. Architects have been using tessellations in their designs for hundreds of years; their applications have varied from intricate interior tilings, like those of the Alhambra Palace in Granada, to light-controlling facades such as those found in Paris' Arab World Institute (Figure 1, middle) and Abu Dhabi's Al Bahar Towers (Figure 1, right). For the most part, these applications have been strictly aesthetic in nature.

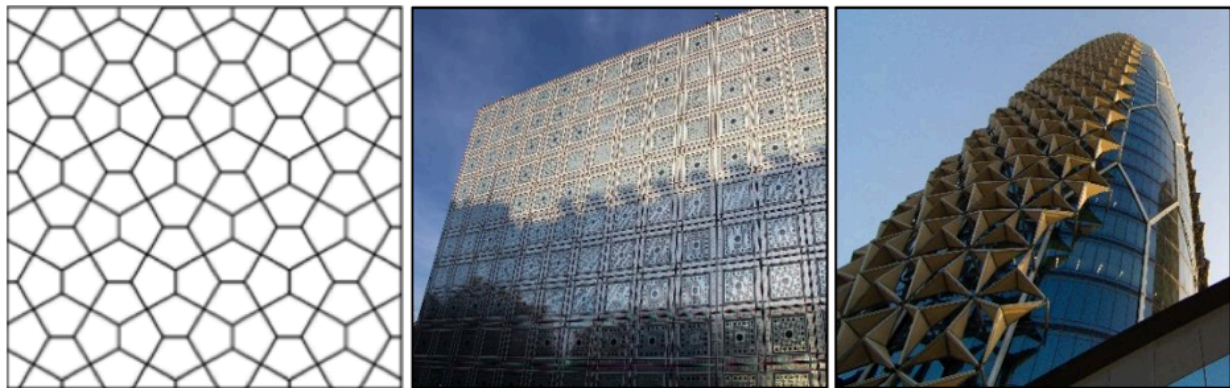

Figure 1: Example of a geometric tessellation (left) (widewalls 2019); Exterior facade of the Arab World Institute (middle) (feach 2006); Exterior facade of Al Bahar Tower (right) (Epsilon 2013).

The work presented in this paper is part of a larger project exploring the use of topologically interlocking tessellations in integrated architectural-structural systems (NSF 2018). For the purposes of this paper, “topologically interlocking” tessellations are defined as tiles which are held together by their interlocking geometry, rather than by a binder or mechanical connection (Figure 2). Existing research on the topic of tessellations has been mainly related to the mechanical behavior of such systems at a small scale. However, an investigation of a full-scale reinforced concrete tessellated structural element has not been performed prior to this study. In fact, the construction of such an element has not previously been attempted.

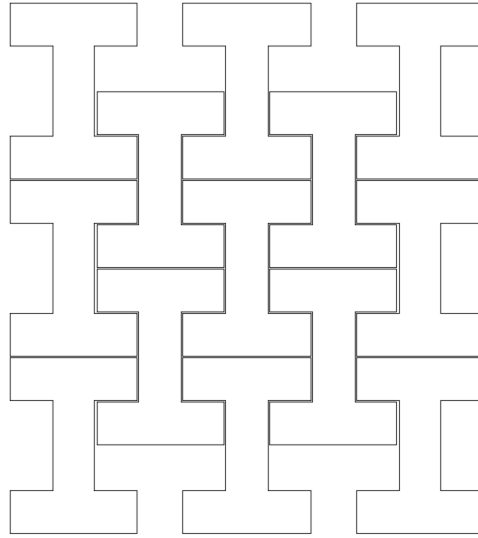

Figure 2: Topologically-interlocking tessellation (no binder or mechanical connection between elements).

This paper describes the process of designing and constructing a precast reinforced concrete TeSA shear wall. Precast was selected as the material for a variety of reasons. The ability to prefabricate the tiles and assemble them in a topologically interlocking pattern on site is highly desirable for a TeSA system. Precast concrete is a highly efficient and cost-effective choice for prefabricating large quantities of identical tiles. Additionally, these precast tiles can be arranged with a certain measure of tolerance to ensure ease of construction. Once all tiles are in place, grout can be used to fill any voids. Another benefit of using precast is the option of using unbonded post-tensioning steel, which could provide a TeSA wall with continuous, but removable, reinforcement. Being able to remove these strands contributes to the ability to replace or reuse individual tiles.

The design and construction of this wall will be explored in depth, as this in itself was an engineering experiment which presented several challenges. Construction methods for a test specimen, which was tested under reverse cyclic loading, will be described. The procedures and results for the laboratory testing of the specimen, as well as technical calculations being developed for theoretical analysis and design of these walls, will not be discussed here; this paper is instead intended to serve as a discussion of the construction process as part of the larger project goals. Papers which will discuss these other topics of interest at length are forthcoming.

SPECIMEN DESIGN

The TeSA shear wall was designed with individually precast I-shaped tiles, which can be arranged in a repeating pattern. This pattern was chosen because it is a relatively simple tessellation. The wall was designed as approximately 9 feet and 6 inches tall and 6 feet and 1 inch long (Figure 3, left). Edge tiles were designed as a portion of the typical I-shaped tiles to form a linear boundary at each edge of the wall. These tiles will be referred to as C-shaped tiles (left/right boundary), T-shaped tiles (top/bottom boundary), and L-shaped tiles (corner boundary). All tiles are scaled to the smallest possible size, which is still large enough to include two-planes of reinforcement with ties, thereby achieving confined concrete cores. The decision to scale the tiles down to such a size

was made based on limits of both budget and experimental space; it should be noted that TeSA systems, as well as the individual tiles that make up the tessellations, could potentially be much larger than this particular specimen. One concern about a wall at this scale is that of out-of-plane load capacity. Scaling the tiles up to the size of the story height of a building would allow this system to be braced out-of-plane by the diaphragms at each floor. Each tile, and therefore the wall itself, is 5.5 inches thick in what will be referred to as the transverse direction (Figure 3, right). Seven unbonded post-tensioning strands were designed to run vertically through the wall in what will be referred to as the longitudinal direction, providing flexural strength and a replicated axial load. Force in these strands corresponds to approximately 6% of the concrete axial load capacity. These strands also provide an additional measure of out-of-plane capacity.

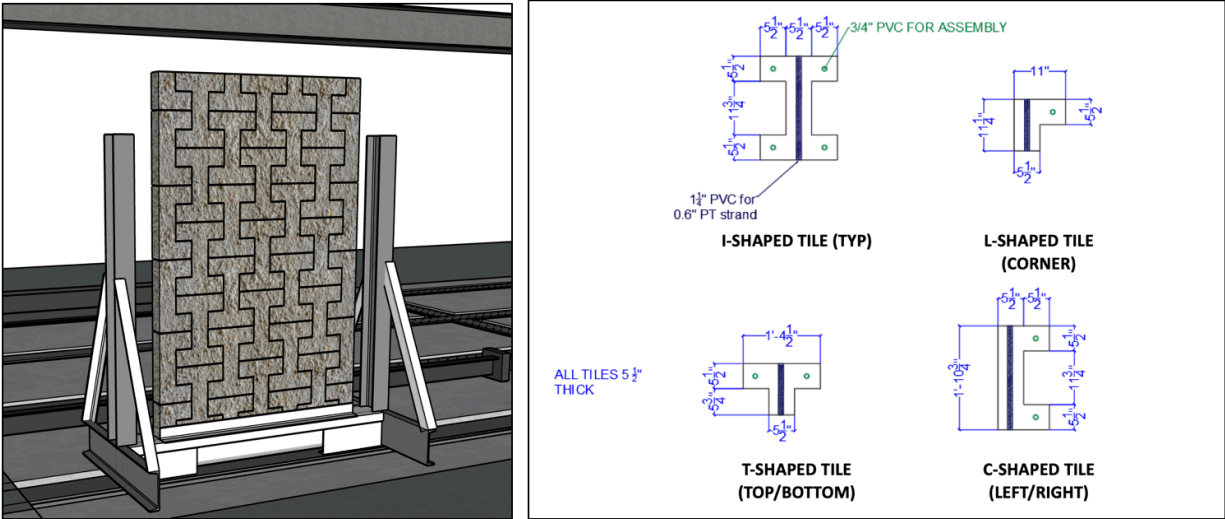

Figure 3: 3D model of TeSA wall specimen (left); Individual tile dimensions (right).

The tiles used to construct the specimen were fabricated at a precast facility using a mix design with a specified compressive strength of 6000 psi. The precaster partner who fabricated the tiles used extra material from the production line at the end of each day; therefore, different batches of the same mix design were used for tiles cast over a period of about 14 weeks. Two specialty forms were designed and built for tile fabrication. Each individual tile was designed with its own discrete reinforcement; #3 ($\phi = 0.375$ inches) bars with a specified yield strength of 60 ksi were selected for all reinforcement based on the limited size of the tiles. Bars were placed with 0.5 inches of cover. An isometric view of tile reinforcement for all tile shapes can be found in Figure 4 (left). Seven 0.6-inch diameter steel strands with a nominal strength of 270 ksi were also selected for the test specimen. A summary of the material properties pertinent to the specimen can be found in Table 1.

Table 1: Summary of material properties.

Material	Specified Minimum Strength
Precast concrete tiles	$f'_c = 6000$ psi
#3 rebar	$f_y = 60$ ksi
0.6 inch diameter steel strands	$f_{ps} = 270$ ksi

Several PVC pipes were also implemented in the individual tile design. One 0.75 inch diameter PVC pipe was designed to run transversely through the tiles at each corner (Figure 4, right). The first purpose of these pipes is to serve as bolt holes at the top and bottom of the wall so that the wall could be bolted to the testing apparatus in the laboratory. The second purpose is to assist in lifting the tiles into place during construction, a process which will be discussed in detail later in this paper.

Another PVC pipe with a diameter of 1.5 inches was designed to pass through the tile longitudinally (Figure 4, right). The purpose of this larger pipe is to provide a hole for the unbonded post-tensioning strands to pass through each tile. A PVC pipe with a significantly larger diameter than that of the strands was chosen to allow greater tolerance during the stacking of tiles, which might mitigate challenges due to potential misalignment of the holes for the strands.

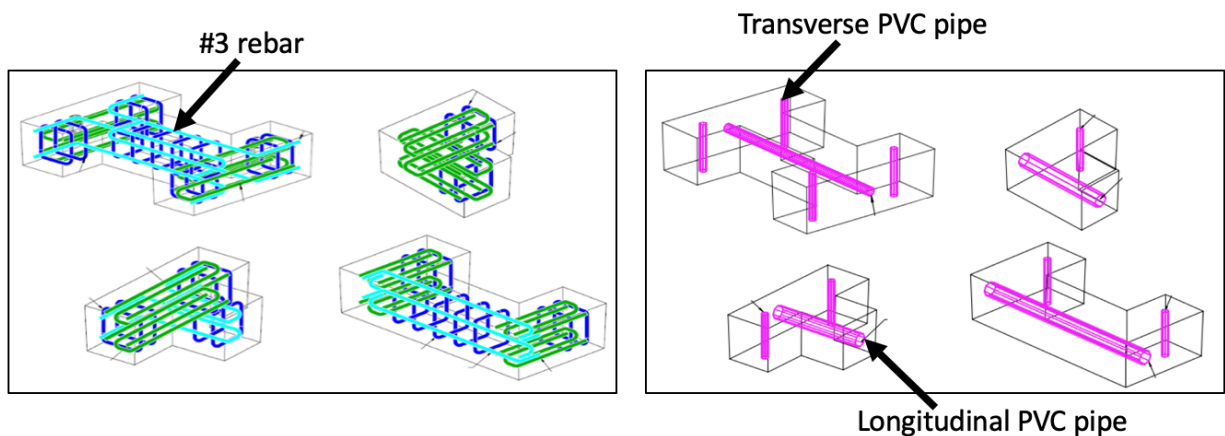

Figure 4: Individual tile reinforcement details (left); transverse and longitudinal PVC pipes (right).

Gaps with a nominal size of 0.375 inches were intentionally designed between each tile. The joints were intended to transfer compressive force through bearing between tiles. Grout was selected to fill these voids; this grout is assumed to have negligible tensile strength in design and analysis. Thus, the tile-tile interfaces were not designed to carry tensile forces. Gaps between tiles provided some tolerance during the construction process. Plastic shims were needed between tiles to maintain consistent spacing. Dry-stacking the tiles was considered, but this process would have made maintaining gaps more difficult and carried the potential risk of spalling at contact surfaces (Atamturktur et al. 2017).

Based on a recommendation by the precaster partner, each tile was designed with a draft of 0.125 inches around its perimeter. This strategy made removal of tiles from the forms easier; however, it also complicated maintaining an average gap size of 0.375 inches between tiles. In order to provide the desired tolerance, the wall design was amended to include a tile flip between each longitudinal row of tiles. As a result, some tiles were separated by a consistent 0.375 inches through the full transverse thickness of the wall, while others were separated by 0.250 inches on one side of the wall and 0.500 inches on the other side of the wall. This arrangement affected the appearance of the wall by causing half of the visible tile faces to be top-in-form (TIF) and the other half to be bottom-in-form (BIF), regardless of which side the wall is viewed from (Figure 5).

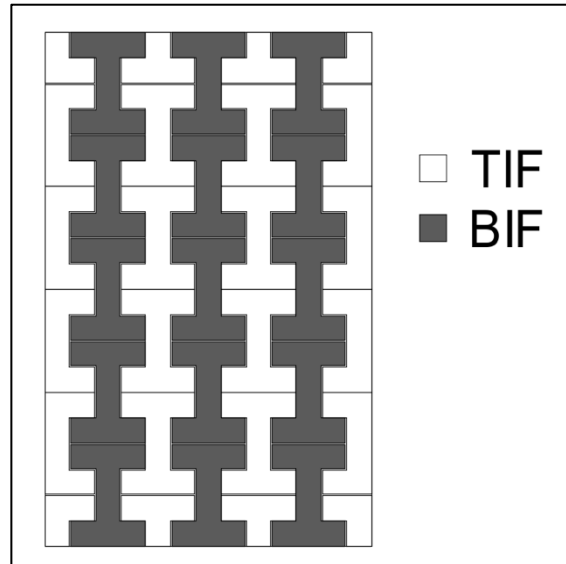

Figure 5: Elevation view of BIF (bottom-in-form) vs. TIF (top-in-form) tile faces from south side of wall.

The decision to implement unbonded post-tensioning in the design of the TeSA wall was based on several factors. Since each tile was designed to be discretely reinforced, the inclusion of post-tensioned steel provided a continuous reinforcement system through the wall. Additionally, unbonded post-tensioned steel has been shown to provide self-centering benefits in reinforced concrete shear walls (Smith et al. 2013). Unbonded strands were selected for ease of construction and removability. One goal of this research is to repair and retest the specimen after an initial test; therefore, removal of the strands is imperative. In addition, compression created by the strands simulated the axial load typically carried by shear walls that do not carry significant gravity loads during testing.

Strand chucks were selected as anchors for the post-tensioned strands. In order for removal of the strands to be possible, easy access to the anchoring strand chucks at both the top and bottom of the wall is crucial. Therefore, a special steel base for the wall was designed which provides this access (Figure 6). The base is a built-up section comprised of plates and angles to form a box. At various intervals along the length of the box, openings were left on one side large enough to fit a hand inside for installation and removal of strand chucks. The base also provides a means for transferring both shear and moment from the wall to the test floor; the test specimen was bolted to the base, and the base was bolted to the floor.

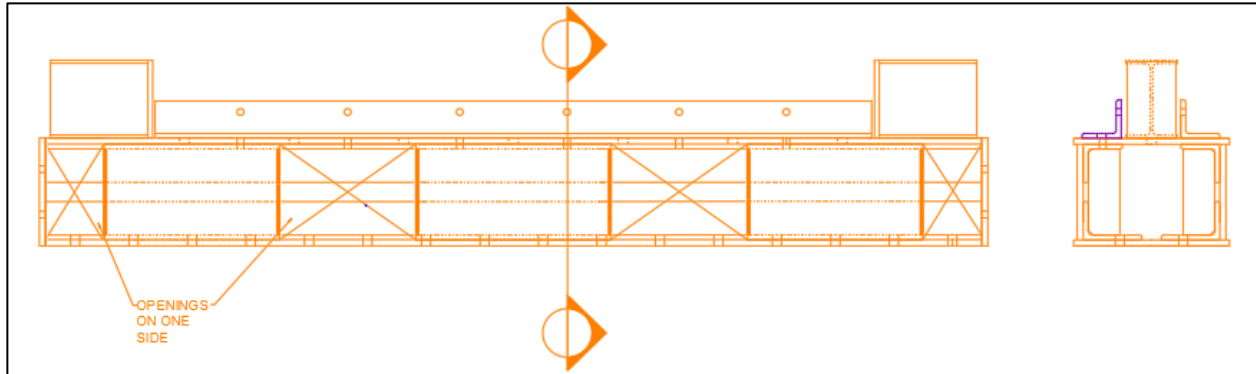

Figure 6: Steel base with openings for strand chuck access.

A steel bracing system designed for the wall can be seen in Figure 7; this system was designed to brace the wall during stacking and to provide out-of-plane support as needed during testing. The horizontal steel angles shown in the figure could be added or removed to this system to aid in construction of the wall. These angles were all removed prior to testing, leaving only two horizontal wide flange members on each side of the wall for out-of-plane support.

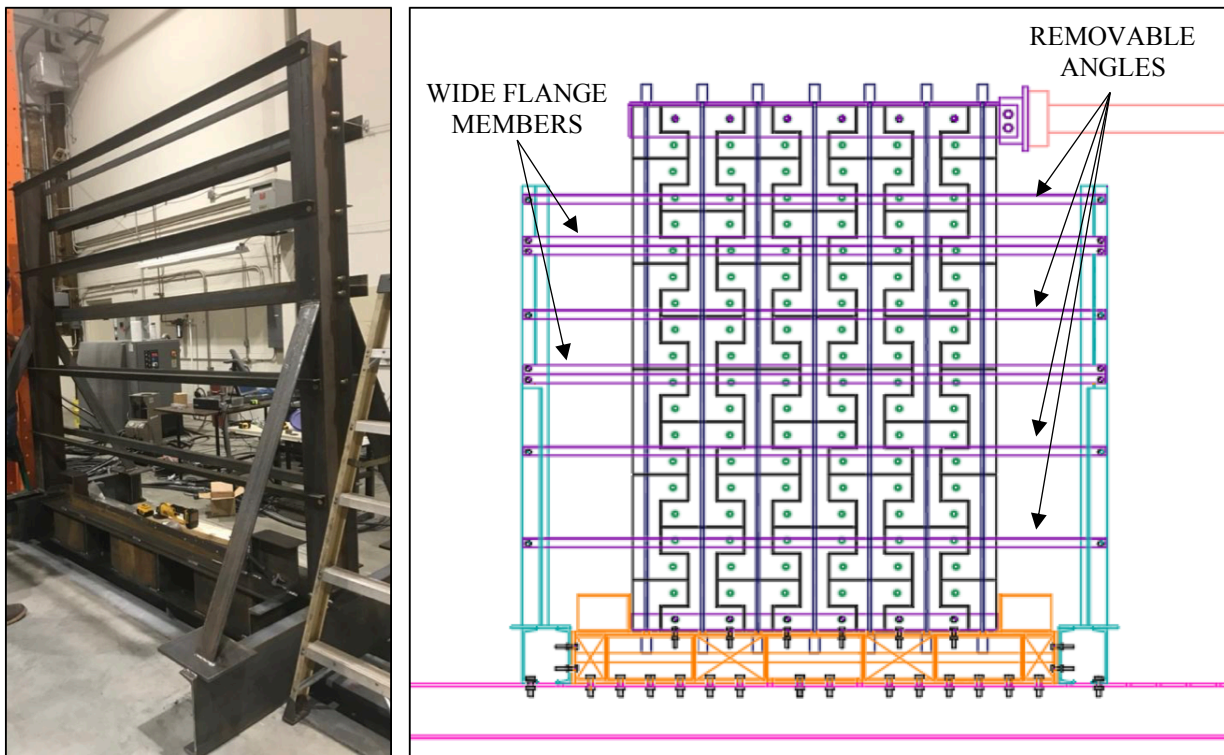

Figure 7: Photograph of steel base and bracing system for specimen (left); Elevation plan for wall and support system (right).

SPECIMEN CONSTRUCTION

The master form concept was used to cast all four tile shapes in just two custom forms. Dividers were installed in the I-shaped master form to create the forms for the other three tile shapes (Figure

8). Spalling was initially an obstacle, likely due to the small amount of cover at the corners of the tiles. However, caulking the joints of the forms and lightly greasing them helped to mitigate this problem (Figure 9). Greasing the forms caused the BIF face of each tile appear slightly darker than the TIF face. Additionally, TIF faces could not be finished due to the cage needed to hold the PVC pipes in place, so they appear rougher than the BIF faces. These aesthetic problems were deemed insignificant for the purposes of this research but may warrant more attention in future design.

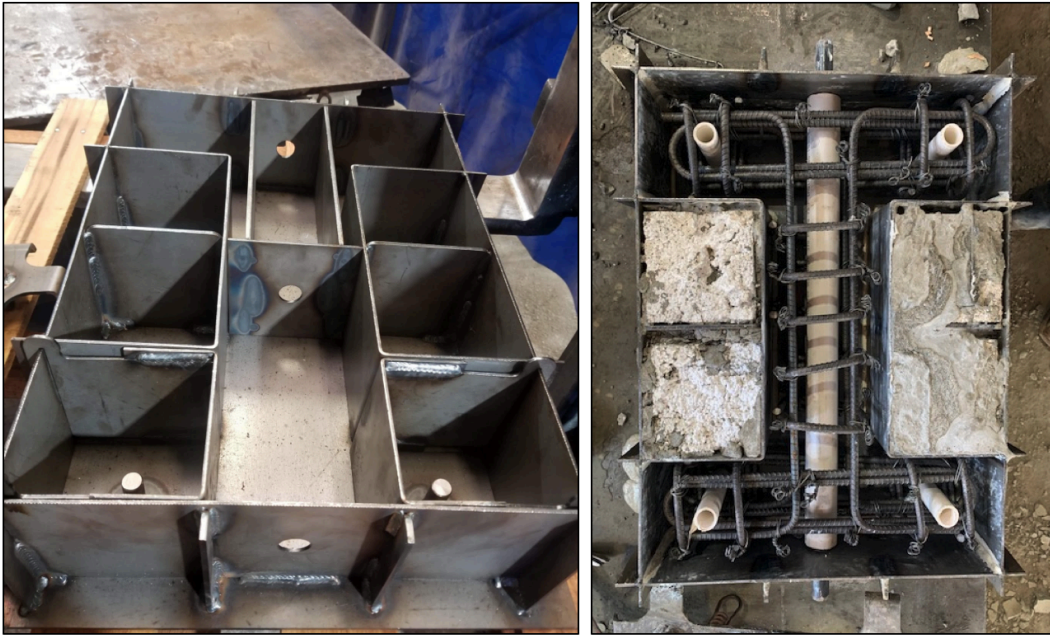

Figure 8: Custom formwork with inserted dividers to form each tile shape (left); formwork with reinforcement just before casting an I-shaped tile (right).



Figure 9: I-shaped tile before greasing forms and caulking joints (left); I-shaped tile after greasing forms and caulking joints (right).

When approximately half of the tiles were cast, a small-scale mockup of the wall was constructed at the precast facility to ensure that tiles would fit together as planned (Figure 10). This stage of the process was crucial, as it provided some insight into the construction process and the problems that might be encountered. It was at this stage that keeping the tiles in plane was realized as a potential challenge. Plastic shims were used to maintain the intended void space between tiles, and several 2 foot long pipes with a diameter of 1 inch were inserted through the longitudinal PVC pipes to ensure that the holes would remain aligned. These practices were adopted throughout the construction process of the full wall specimen when it was stacked in the lab. Alignment “straps” were also used during construction of the mockup; these straps were small steel plates with two holes that could be bolted through the transverse PVC pipes to keep the tiles in plane. However, these straps were not efficient during construction of the full wall test specimen due to several factors, including the slight offset between holes of adjacent tiles and the required removal of the straps during the grouting process.

It was also at this stage of the process that an exception had to be made to the alternating TIF/BIF arrangement of the tiles. All L-shaped corner tiles were cast identically; however, two of these L-shaped tiles would need to be mirrored in order to maintain the planned design. It was determined that this challenge could be overcome by adjusting the tolerances around those two tiles and grouting as needed, rather than casting new L-shaped tiles.



Figure 10: Small mock-up constructed at precast facility.

Building on lessons learned from the mockup, construction of the full wall test specimen began. A 0.25 inch layer of grout was applied to the steel base before laying the first row of tiles. Because of the draft on the tile edges, the base layer of grout spread to be thicker on the BIF side and thinner on the TIF side of the tiles. Subsequent rows were lifted into place using a chain hoist (Figure 11). The chain hoist was selected due to the relatively small nature of the wall; however, it proved time consuming to lift each tile manually in this manner. Future assembly might be better executed with a crane or other mechanical lift, particularly for assembly of a larger system.



Figure 11: Lifting strategy for tiles using chain hoist.

Shims of appropriate thickness were placed around the edges of the new tile interface as needed just before installing each tile. Tiles were required to be slid into place after placing the first row, rather than being simply being stacked (Figure 12, left). Once the tile was roughly in place, a 1 inch diameter pipe steel pipe with a length of 24 inches was inserted through the longitudinal PVC pipe to ensure that it was aligned with the PVC pipe of the tile directly below it. The pipe had a flange on one end to prevent it from completely sliding into the vertical PVC pipes. With the 1 inch pipe and shims still in place, non-shrink grout was inserted in the gaps around the tile in a dry-pack consistency. Due to the draft of the tiles, shims of different thicknesses were sometimes required on opposite sides of the same gap; these shims were intentionally placed as close to the edges of the tiles as possible to allow grout to be packed around them before removing the shims. The tile was monitored throughout this process to ensure that it remained level and in-plane. Removable horizontal angles were added and removed as needed to provide safety and stability throughout the process (Figure 12, left). Once grouted in place, the alignment pipe and shims were removed. This process was repeated row by row for the entire wall (Figure 12, right).



Figure 12: Each successive row could be slid into place by adding and removing angles during construction process (left); Fully stacked wall (right).

Upon completion of the tile stacking process, a steel “cap” was placed on the top face of the wall to provide a bolted connection to the hydraulic actuator used to load the wall in experimental testing. This cap was designed to transfer lateral force from the actuator to the wall via a bolted connection through the transverse PVC pipes of the top row of tiles (Figure 13, left). A significant challenge was encountered at this stage; although the tiles had remained fairly well-aligned in the longitudinal direction throughout the construction process, the combined effect of the very small misplacements in tiles caused the wall to be approximately 0.75 inches wider (73.75 inches rather than 73 inches) than planned during design. As a result, only two of the six bolt holes aligned with their respective transverse PVC pipes. The consequence of this was that the steel cap had to be modified to provide a transfer of force through bearing, which was initially undesirable due to the possibility of spalling at the contact surface. A possible solution to this problem in future testing could be to cut holes in the cap after erection is complete. Alternatively, and preferably, construction performed by a skilled tradesperson with experience in masonry would potentially mitigate errors that could lead to such problems.

After placing the steel cap, the wall was painted white to increase crack visibility. At this point, installation of the post-tensioned strands began. Strands were first passed through the longitudinal PVC pipes from the top of the wall. Strand chucks were placed inside the steel base to anchor the strands at the bottom of the wall. A steel “saddle” was designed and fabricated to provide a seat for the hydraulic jack used to stress the strands (Figure 14, right). The saddle features a hole to feed the strand through, as well as a hollow interior with enough room to reach a hand in and secure the strand chuck to anchor the strand at the top of the wall before removing the hydraulic jack. The strands were stressed to provide a tension force of 22 kips in each 0.6 inch diameter strand, or a stress of just over 100 ksi. Strands were stressed from the inside-out to maintain approximately uniform vertical stresses in the wall (Figure 13, left), considering elastic shortening.

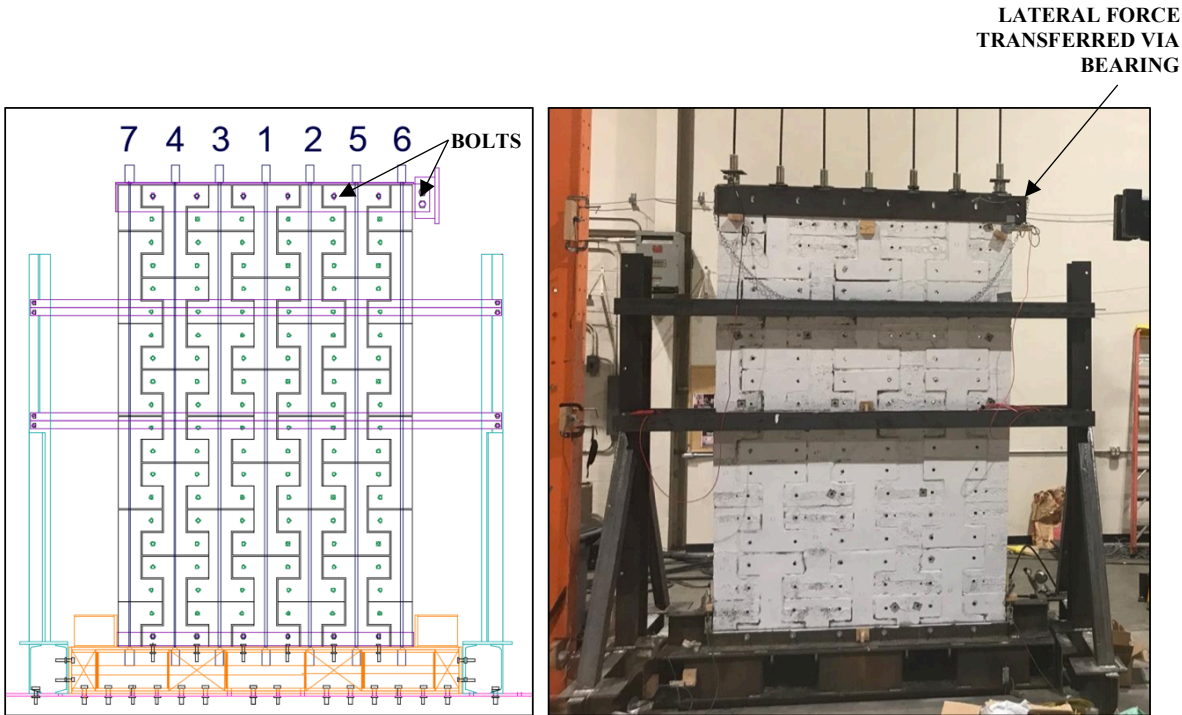

Figure 13: Elevation drawing of wall with strands and initial design for steel cap connection (left); Photograph of completed wall with post-tensioning installed, as well as modified steel cap (right).

A problem encountered during this phase of construction, related to the difficulty of stressing the outermost strands due to their proximity to the edge of the wall. The dimensions for the steel saddle were selected to allow enough room for the strand chuck, as well as a hand, in the hollow interior. However, its size made it almost too large to sit on the edge of the steel cap for the outermost strands. A plate was added under each of the supporting angles with a small lip to provide additional bearing area during the stressing process (Figure 14, right).

After the strands were stressed, a hydraulic actuator was set up and placed in contact with the wall to conduct a reverse cyclic loading test. Details of the test program and associated analytic program will be presented in forthcoming publications.



Figure 14: Steel saddle at edge before adding supporting plates to bottom (left); strand jacking setup with supporting plates added to saddle (right).

CONCLUSIONS

This paper discussed the design, fabrication, and assembly of a precast concrete TeSA wall test specimen. The challenges of building this new structural system proved to be significant, and it is anticipated that similar challenges will arise upon repairing the system. The most significant lessons learned from this process include:

- Precast concrete is an efficient and economical choice for TeSA systems. The ability to prefabricate many identical tiles using a small number of forms is valuable. In the future, the tolerance benefits of precast could be better utilized to make construction of TeSA walls easier.
- Building a mock-up was critical in understanding how the tiles fit together and helping foresee potential problems.
- The stacking and grouting processes were time-consuming; there was a learning curve. Arranging tightly interlocking tiles and attempting to apply grout between them proved to be a challenge for which a skilled tradesperson would be crucial to achieve high quality results, particularly in a larger scale TeSA system.
- The longitudinal PVC pipes for the post-tension strands lined up well through use of a temporary alignment pipe during stacking. A smaller diameter PVC pipe for the strands could possibly be used in the future that will allow more concrete cover, but the 1.5-inch diameter pipe worked well for this specimen.
- Challenges stemmed from the draft of the tiles and its effect on the gap dimensions between each tile. In particular, it was essential to correctly arrange tiles based on bottom-in-form (BIF) and top-in-form (TIF) faces, otherwise they would not fit together properly. Dry-finishing TIF faces could help improve the appearance to provide a more uniform look. Using shims with adjustable thickness proved helpful in maintaining the appropriate gap

sizes. In the future, draft-related challenges could be avoided by investing in collapsible formwork which would allow tiles to be cast with flat sides.

- The steel alignment straps used in the construction of the mock-up were helpful in keeping the tiles in-plane, but were less practical in full wall construction due to joint size variations based on draft and the grouting process. Something similar to the straps may be helpful in the future, but the design requires further development for full-scale implementation.

It is the intention of the authors to document and detail the design and construction of a reinforced concrete TeSA wall, as well as to provide guidance for any future endeavors in the construction of a similar structural system by examining these challenges and solutions. Future reports on this project will include reverse cyclic loading procedures and results for this specimen.

ACKNOWLEDGEMENTS

This research project is being funded through the United States National Science Foundation. The project title is “Collaborative Research: Tessellated Structural-Architectural Systems for Rapid Construction, Repair, and Disassembly” and is conducted under award numbers 1762899 and 1762133.

Fabrication and erection assistance was provided by Clemson Machining and Technical Services, Clemson technical staff member Scott Black, and Clemson student Sam Dodd.

Materials for the project were donated by Tindall Corporation, Prestress of the Carolinas, General Technologies, Inc., JVI, and Dayton Superior.

REFERENCES

- Atamturktur, S., Ross, B. E., Thompson, J., and Biggs, D. (2017). “Compressive strength of dry-stacked concrete masonry unit assemblies.” *Journal of Materials in Civil Engineering*, 29(2), 06016020. doi:10.1061/(asce)mt.1943-5533.0001693
- Image by Tessellation Patterns - From Mathematics to Art. (n.d.).
<https://www.widewalls.ch/magazine/tessellation-mathematics-method-art>, retrieved 2019
- Magnus, W. (1974). *Non-Euclidean Tessellations and Their Groups, Pure and Applied Mathematics*, Volume 61. Academic Press, New York, 207.
- NSF Award SEARCH: Award#1762899 - COLLABORATIVE Research: Tessellated Structural-architectural systems for Rapid Construction, repair, and disassembly. (2018). Retrieved February 24, 2021, from
https://www.nsf.gov/awardsearch/showAward?AWD_ID=1762899&HistoricalAwards=false
- Photograph by fee-ach. (2006). L'institut Du Monde Arabe (Image Modified from the Original),
<https://flic.kr/p/HkYhZs>. Available for use under license:
<https://creativecommons.org/licenses/by-sa/2.0/legalcode>, retrieved 2017.

- Photograph by Epsilon, S. (2013). Al Bahar Towers - Responsive Facade, <https://flic.kr/p/ezQiGU>. Available for use under license: <https://creativecommons.org/licenses/by-sa/2.0/legalcode>, retrieved 2017
- Ross, B. E., Yang, C., Kleiss, M.C., Okumus, P., and Elhami Khorasani, N. (2020). “Tessellated Structural-Architectural Systems: Concept for Efficient Construction, Repair, and Disassembly,” *Journal of Architectural Engineering*, v.26.
- Smith, B., Kurama, Y., and McGinnis, M. (2013). “Behavior of precast concrete shear walls for seismic regions: Comparison of hybrid and emulative specimens.” *Journal of Structural Engineering*, 10.1061/(ASCE)ST.1943-541X.0000755, 1917–1927.